



Installation Instructions



CAUTION: An experienced technician familiar with the use and handling of high-pressure cryogenic gases should install this system. If you have any doubt about your skills this system should be taken to a qualified shop for installation. If you have decided to do the install yourself please read and understand all of these instructions before you start. Some of these instructions may or may not apply to your vehicle, if you have any questions please call our tech department 940-767-7694 9:00A.M.-5:00P.M. CST.

Before starting, disconnect the negative terminal on the battery. If you have any questions about your particular vehicle consult a shop manual.

These instructions are divided into 6 sections:

1. **Mounting the Bottle & Routing the Supply Line**
2. **Mounting the Nozzle & Solenoids**
3. **Plumbing the Fuel System**
4. **Wiring**
5. **Testing the System**
6. **Power Tuning Tips**

Before starting any installation steps:

1. Never use Teflon tape on any system fittings. Tape debris will cause numerous problems ranging from clogged solenoids to blocked jets. Use the liquid thread sealer furnished with your NX system. A drop is all it takes.
2. Have your nitrous bottle filled by a reliable source, being sure it is filled to the correct capacity with **FILTERED** "NY-TROUS+" nitrous oxide.

MOUNTING THE BOTTLE

The nitrous bottle should be mounted in the trunk area or outside of the passenger compartment. If this is not possible or practical a NHRA approved blow down tube and vent fitting (PN's 11708, 11709) must be installed; on the Proton System Part # 20420-xx it is required to replace the bottle valve with an NX lightning bottle valve (part # 11700L) when using the NHRA Safety fittings. The positioning of the bottle should be as shown in illustration "A". This will allow the siphon tube to be covered at all times. The mounting brackets should be assembled on the bottle with the short bracket approx. 2" from the bottom. The long bracket should be place approx. 7" above the lower bracket on 10lb bottles. The upper bracket should be approximately 12" above the lower bracket on 15lb bottles.

Note: Before drilling holes to mount the bottle, be sure to check for clearance beneath the mounting surface i.e.: fuel tank, fuel lines, brake lines, etc.

ILLUSTRATION A

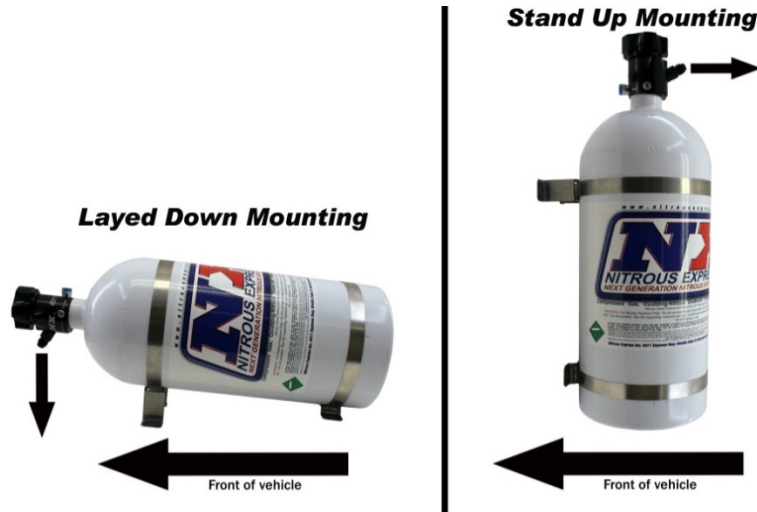

To route the supply line, drill a $\frac{3}{4}$ " hole beneath the valve discharge port. Before beginning the routing procedure; place tape over both ends of the line. Now route the line beneath the car being sure to avoid all exhaust, suspension and other moving parts. Following the factory fuel line is usually the safest. Be careful to avoid any positive 12-volt sources, one small spark to the outer braid of the line will destroy it!!! Secure the line carefully, zip ties work best here. Before connecting the line to the bottle, purge the line of all possible debris by carefully blowing compressed air through the line for several seconds. Connect the line to the bottle nipple and tighten securely.

MOUNTING THE N2O/FUEL MANAGEMENT SYSTEM & NOZZLE:

If you are installing a Proton system with the Piranha Nozzle, follow the instructions in section A below. If you are installing a Proton Plus system with the Shark Nozzle, skip to section B below.

Section A: Mounting the nitrous nozzle without a nozzle mounting adapter.

1. Remove the air inlet tube. Drill a hole in the location you have chosen for the nozzle placement. Tap the hole with a pipe tap that matches the threads on the nitrous nozzle.
2. Using red thread sealer, thread the nozzle into the air intake tube and tighten, aligning the nozzle discharge toward the throttle body. (The arrows in illustration "B" show the proper nozzle orientation.)
3. Using the horsepower jetting chart select the desired jets. Insert the jets into the nozzle fittings being sure to insert the correct nitrous and fuel jets into the correct fittings. Note: The larger jet # always goes in the fitting marked "Nitrous"
4. After installing the jets into the nozzle using the supplied 3AN Fuel and nitrous hoses, connect the Nitrous/Fuel Management System to the nozzle, paying attention to connect the Nitrous out port to the fitting labeled Nitrous on the nozzle and the Fuel out port to the fitting labeled Fuel
5. Using a backup wrench, connect the previously cleaned nitrous supply line to the Nitrous Inlet port and tighten securely.

Section B: Mounting the nitrous nozzle with a nozzle mounting adapter.

1. Remove the air inlet tube. Drill a $\frac{9}{16}$ " hole in the location you have chosen for the nozzle placement. This area should be as flat as possible to assure proper sealing of the nozzle adaptor.
2. Using a "sensor safe" silicone RTV type sealer; apply a thin bead around the nozzle adaptor sealing surface. Insert adaptor from the inside of the air inlet tube and snug the locking nut against the outside

of the air intake tube. Thread the Shark nozzle into the adaptor and tighten, aligning the nozzle discharge toward the throttle body. (The arrows in illustration “B” show the proper nozzle orientation.)

ILLUSTRATION B

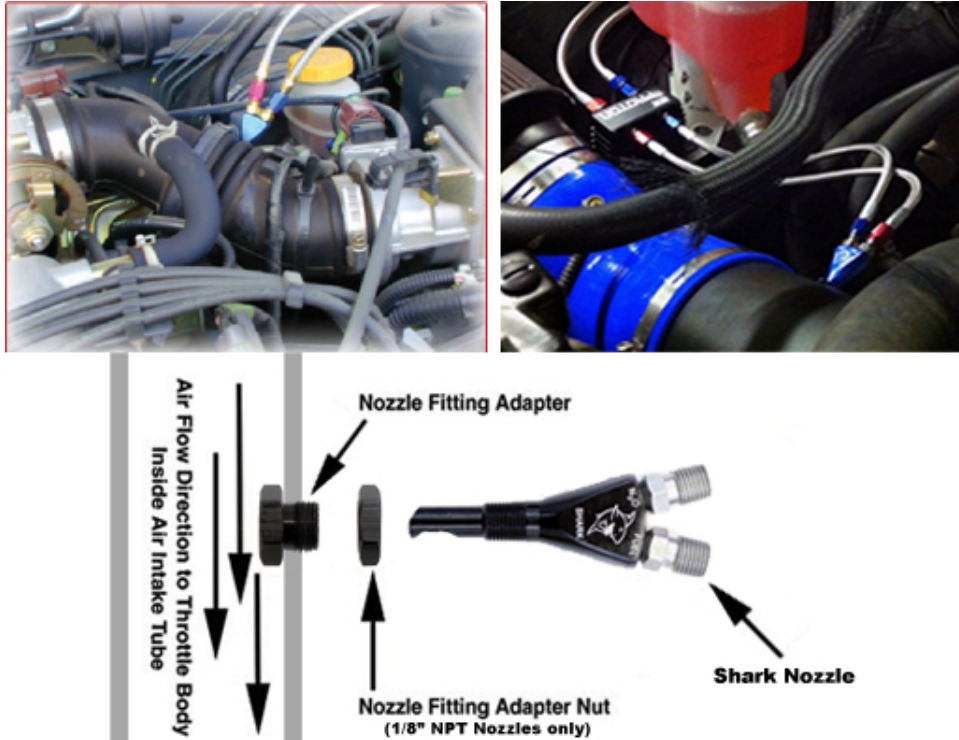

NOTE: ALL HOSES MUST BE INSTALLED WITH A BACKUP WRENCH ON SOLENOIDS!

Plumbing the Fuel

1. Many vehicles have a “test port” fitting on the fuel rail which is used by mechanics for checking fuel pressure. This is usually covered by a black plastic cap and is where the 4an fuel feed line will be connected. Note: Care should be taken to be certain the port you have selected is the “Fuel Test-Port”. Many late model cars have several similar ports that do not contain fuel.
2. Remove the protective cap from the test port fitting. Using a valve core wrench, (valve stem core remover) remove the inner core from the test port fitting. (Recommend using a proper mechanics shop rag over the fitting to avoid excess fuel spillage). Check thread compatibility with fitting on 4an stainless fuel line. (See Illustration C)
3. If your vehicle does not have a test port then the supplied Tee fitting must be spliced into the factory fuel line. The line spliced must be the high pressure side (not the fuel return). Choose a location between the fuel filter and the EFI fuel rail, cut the hose and insert the Tee using the supplied clamps, tighten the clamps securely. **Caution: When cutting any fuel lines, be sure to prevent any debris from entering the fuel system. Debris can cause a catastrophic engine failure due to clogged fuel jets or injectors.**
Note: If your vehicle has a rigid plastic fuel line, an alternate method to tap this line must be used. Do not attempt to cut this type of line. NX Offers direct plug in fuel line adapters for most vehicles.
4. Now connect the 4an fuel line from the fuel supply to the inlet side of the fuel solenoid.

ILLUSTRATION C



Wiring the System without a relay

Proton Wiring

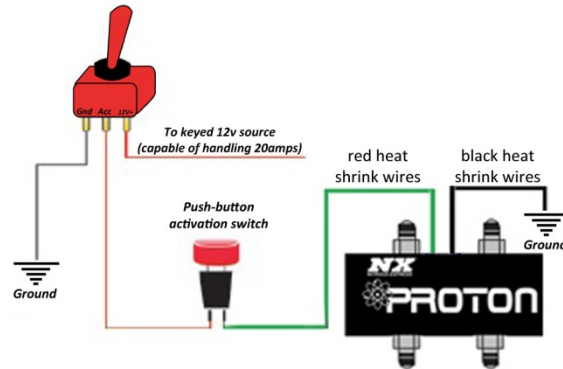

Wiring the System with a relay

Proton Plus Wiring

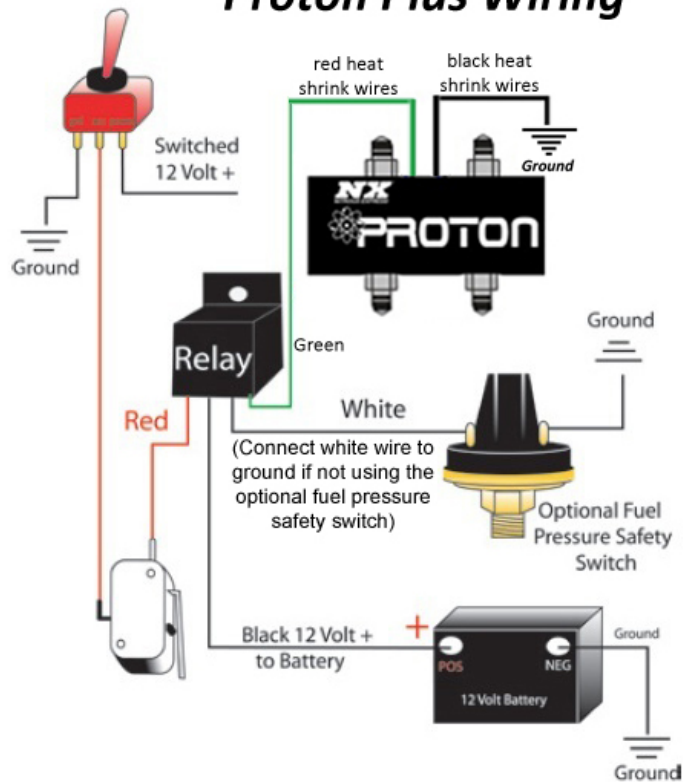

NOTE 1: The wires in the red heat shrink tubing go to positive (+12v), green wire on the relay, and the wires in the black heat shrink tubing go to negative (ground).

Proton Plus Fly-by Wire Wiring

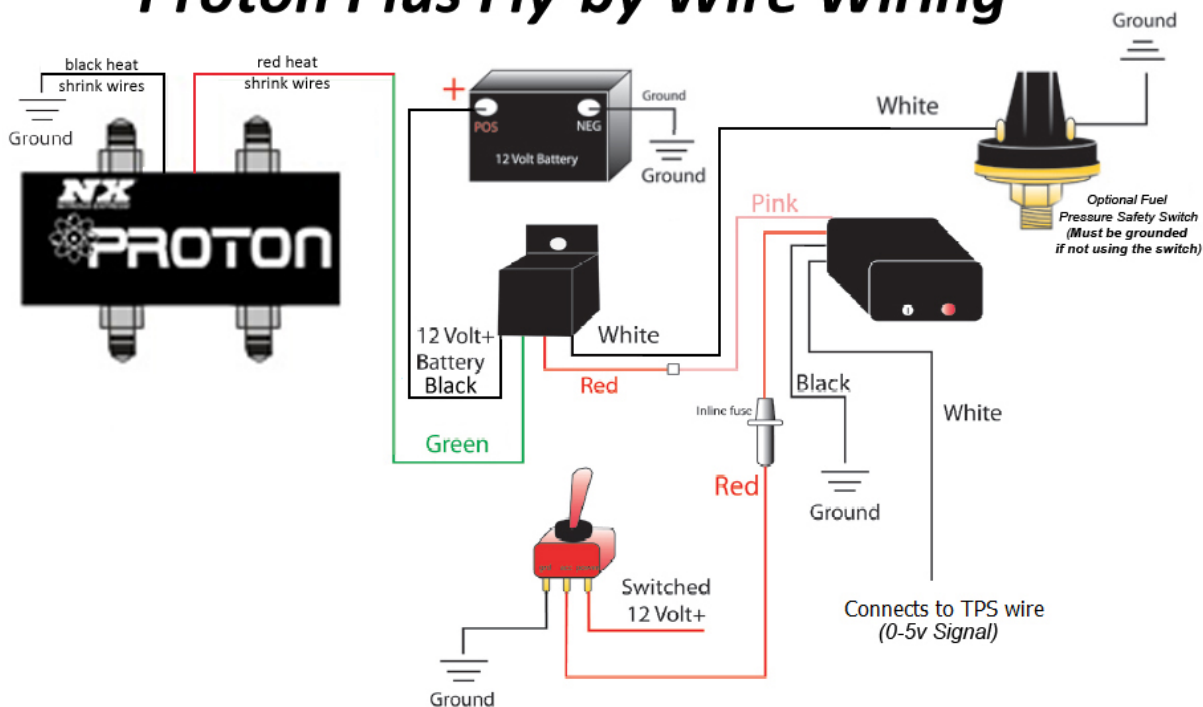

NOTE 2: The blue wire of the relay is not used.

Follow the wiring diagram below that matches the system you have. For proper operation do not vary from this diagram. Solder and seal all connections with tape or heat shrink tubing (recommended)

Testing the System

1. Re-check all installation procedures to be sure nothing has been omitted.
2. Be sure the nitrous bottle has not been opened and the supply line is empty!
3. Reconnect the Negative battery cable.
4. Using the toggle switch "ARM" the system.
5. Test solenoid operation by using the system activation switch. Both solenoids should "Click" (The nitrous solenoid should click loud, and the fuel solenoid will click soft). If they do not, re-verify all electrical connections and wiring diagrams.
6. Carefully open the nitrous bottle and verify that no fittings or hoses are leaking. Correct any leaks before proceeding.
7. Do not start the engine if nitrous has been accidentally injected while the motor was not running! All nitrous must be cleared from the engine before starting; otherwise a violent intake manifold explosion could occur!
8. Start engine and check for any fuel leaks. Correct any leaks before proceeding.
9. The PROTON Nitrous System is now ready for normal usage.
10. All NX systems are intended for off road use only and should only be used in that context.

Note: The Nitrous/Fuel Management System is rated for intermittent duty only. Do not engage Nitrous/Fuel Management System for more than 20 continuous seconds. Units that have been abused or over heated will not be replaced under warranty.

Additional parts recommended for operating your PROTON nitrous system satisfactorily:

- Nitrous Pressure gauge (PN 15509) - STRONGLY RECOMMENDED
- Purge Valve (PN 15600)
- Bottle Jacket (PN 15945)
- Fuel pressure Safety Switch (PN 15718)
- Bottle heater (NX 15940) - STRONGLY RECOMMENDED
- NHRA legal blow down vent fitting (PN 11709)
- NHRA legal blow down vent tube (PN 11708)
- Direct plug in EFI fuel rail adapters (see nitrousexpress.com for part numbers)

SAFETY TIPS

Do not attempt to start engine if nitrous has been accidentally injected while the engine was not running. Disconnect coil wire and turn motor with throttle wide open for several revolutions before attempting to restart. If it is not possible to disable the ignition then the spark plugs must be removed and the engine cleared of all nitrous before attempting to start engine.

1. Never permit oil, grease, or any other readily combustible substances to come into contact with nitrous cylinders, valves, solenoids, hoses and fittings. Oil and certain gases (such as oxygen and nitrous oxide) may combine to produce a flammable condition.
2. Never interchange solenoids or other appliances used for one compressed gas with those used for another.
3. Identify the gas content by the label on the bottle before using. If the bottle is not identified to show the gas contained, return the bottle to the supplier.
4. Do not deface or remove any markings, which are used for content identification.
5. Cylinder valves should be closed except when nitrous is actually being used.
6. Notify supplier of any condition, which might have permitted any foreign matter to enter the valve or bottle.
7. Never drop or violently strike the bottle
8. Keep valves closed on all empty bottles to prevent accidental contamination.

POWER TUNING TIPS:

Nitrous oxide works well with all applications; 4 cycle, 2 cycle, diesel, and rotary engines. Each one has individual tuning characteristics, and these tips apply generally to each one. Nitrous oxide is referred to as "Liquid Supercharging" because it, in effect, does the same thing as a mechanical supercharger, adding more fuel and oxygen into each cylinder, thus producing more power. The biggest enemy of all supercharged, turbo charged and nitrous injected engines is "DETONATION". The use of higher-octane fuel, and or a combination of better fuel and timing retard can control this. Remember detonation is a spark plug, head gasket and engine "KILLER".

1. Your engine should be tuned to its maximum power prior to nitrous usage.
2. The ignition is an integral part of the nitrous system and must be able to ignite the mixture under very high cylinder pressures. The hotter the spark the better!
3. In stock engine applications and street usage the spark plugs should be at least 2 steps colder than stock. Do not use platinum tip, extended tip or any plug with multiple ground straps or split ground straps. When in doubt about heat range always go one step colder. A spark plug that is to "Hot" will cause detonation, burned plugs, poor performance, and engine damage. In competition engines always use the coldest plug available. Never use an extended tip plug in a racing engine.

4. The NX nitrous system is so advanced, (technology, engineering, and workmanship) that huge amounts of timing retard is not required. We recommend 2 degrees timing retard for each 50 horsepower boost as a starting point. Your engine may need more or less depending on your combination.
5. Your fuel system is also an integral part of the nitrous system, be sure it is in top shape and all filters are clean.
6. Engine operating temperature should be between 160 and 200 degrees prior to nitrous usage.
7. Never "lug" your engine and hit the nitrous system, use the system at wide-open throttle only, nitrous should not be used below 3000 rpm's. If you do any of the above a serious "Back Fire" could result in engine damage.
8. The better the exhaust system the better the nitrous system will work.
9. Do not attempt to drill or alter the jets, solenoids, or the tubes in the nitrous plate. These items are engineered to their maximum capability. Any modification you can make will decrease power and destroy engine parts.
10. Do not mix or attempt to match any other brand solenoids, plate, or nozzles with this system. Any attempt at this could lead to serious engine damage.
11. All of our systems are designed to operate at 1000 PSI bottle pressure. This is extremely important and cannot be stressed enough. If your bottle pressure is below 1000 PSI the system will run rich and will not produce the advertised horsepower. If the bottle pressure is above 1000 PSI the system will run lean, possibly damaging engine parts. This pressure is easily monitored by using a NX liquid filled pressure gauge (PN 15509). Note: When the ambient temperature is below 97 degrees a bottle warmer is required (PN 15940 or 15941). An NX bottle jacket (PN15945 or 15946) will help stabilize bottle pressure in the winter and summer.

CAUTION: NEVER USE AN OPEN FLAME TO HEAT A NITROUS BOTTLE. THIS IS A VERY DANGEROUS AND POTENTIALLY FATAL PRACTICE!!!!!!!!!!!!!!

12. A purge valve (PN ML15600) is recommended on all NX systems. When the weather begins to get hot a purge valve is worth up to a tenth of a second on a 1/4 mile pass. Note: The correct purging procedure for drag racing is: 1. Complete the burnout. 2. Light the pre-stage bulb. 3. Push the purge button three times, one second each. 4. Stage immediately, GO FAST.
13. If there is a question about the purity of your nitrous supply, a filter (PN15610 or 15607) should be used when refilling your bottle. Just attach the filter to your bottle when you take it to be refilled. Contaminated nitrous will cause serious damage to the nitrous solenoids and possibly to your engine. This is a lifetime renewable filter.
14. If you have questions about the suitability of your torque converter or gear ratios, call the factory tech line for the inside scoop.
15. Your nitrous bottle should be turned off when not in use (even between runs). An NX remote bottle opener (PN 11107) will make this task much easier.
16. Start with the lowest power setting in your system. Don't try to be the track "Hero" on your first pass. Remember start out small and work your way up, NX systems produce more real horsepower than any other brand on the market today.
17. If the solenoids must be disassembled for cleaning or rebuilding always use the proper wrench (PN 15921). Do not use any clamping devise on the solenoid tower, instant non-warranty, damage will result.
18. If you run an NX system of 150+ horsepower you must use a high octane racing type fuel. These are some tips to help you choose and maintain the correct fuel for your application:
 - A. The most important statistic you should look for in the fuel specifications is the "MON" or motor octane number. In most cases the higher the number the more timing you can run and detonation will not be a problem
 - B. Most V-8 or V-12 engines with stock compression will run on "93" unleaded pump gas with up to 150 horsepower boost, most 4 or 6 cylinders with stock compression can use up to 75 horsepower.
 - C. Racing engines with high compression or higher must run racing fuel. The higher the compression, and the higher the boost, the higher the "MON" must be.

- D. With nitrous usage usually the highest "MON" available is the one that should be used.
 - E. All NX systems are calibrated to use fuel with .730 specific gravity or "SG". If you use a fuel with a lower "SG" you must use a larger fuel jet to compensate for the lighter fuel. If you use a fuel with a higher "SG", a smaller fuel jet will be required. Most unleaded pump gas is .730 SG or above.
 - F. Racing fuel should be stored in an airtight, dark container. Exposure to atmosphere allows very important elements to evaporate, lowering the octane of the fuel. Sunlight oxidizes the lead contained in racing fuel, since this is the most important ingredient used to raise octane it must be protected.
 - G. Never leave the fuel in your car between race days. This allows evaporation of the very important "High end" hydrocarbons and lowers the octane of the fuel.
 - H. Never buy racing fuel from an underground or vented storage tank. Always demand to see where and how the fuel is stored; a sealed drum is the only correct way.
 - I. AV gas or aviation fuel is not compatible with nitrous usage, don't be tempted by the cheap price, instant engine damage will result!
 - J. For a fuel recommendation, contact your NX dealer.
19. All vehicles, including full competition race cars, must have an alternator to provide adequate amperage required by today's racing accessories. Add up all the amps required by your car, you'll be surprised!
20. If you have trouble with your NX system or any related parts, call your dealer first. If you still need help call the factory tech line 940-767-7694 9:00AM-5:00PM CST Mon-Fri. We are the nitrous experts and will give straight answers to your questions.

In conclusion.....

This instruction sheet and power tuning tips are valid only for a NX system. If you have a kit from another manufacturer this information will not help you! A tune up from any other brand of nitrous kit will not work with the NX "Next Generation" technology.

DO NOT LISTEN TO:

- A. YOUR BUDDY!
- B. YOUR BUDDY'S FRIEND!
- C. THE LOCAL NITROUS GURU!
- D. ANY ARTICLE IN ANY MAGAZINE

If you follow the foregoing suggestions, your NX system will operate trouble free and provide years of thrills.
ABOVE ALL REMEMBER TO RACE SAFE AND HAVE FUN!

Proton EFI Single Nozzle

Select the desired horsepower level and fuel type to determine the nitrous and fuel jet requirements i.e. if you have a Proton EFI Single Nozzle System, and want a 150 HP boost you would use a 62 Nitrous and a 37 Fuel jet with 45-55 flowing fuel pressure. Spark plugs should be at least 2 steps colder than stock gapped no larger than .035. Do not use platinum tip, extended tip or any plug with multiple ground straps or split ground straps. When in doubt about heat range always go one step colder. Ignition timing should be retarded 2 degrees per 50 hp of nitrous being sprayed.

CHECK ALL JETS FOR OBSTRUCTIONS UPON INSTALLATION!!!!!!!!!!

Proton EFI Single Nozzle					
	HP	N20	Gasoline	E85	Flowing fuel pressure
	35	31	18	20	45-55
Highlighted jetting is included with system	50	35	20	22	45-55
	75	41	23	25	45-55
	100	52	28	32	45-55
	125	57	33	34	45-55
	150	62	37	38	45-55

This jetting chart is for informational purposes only, NX is not responsible for misuse or misapplication.