



*NX #15835
Installation & and User Guide*



NX #15835

Table of Contents

1.0—Important Information	Page 2
2.0—Controller Description, Basics of Operation	Page 3
3.0—Setting the Nitrous Power Ramp	Page 4
3.1—Setting the Start Percent	Page 4
3.2—Setting the Build Time	Page 4
3.3—Example Nitrous Power Graph	Page 4
4.0—Installation Basics	Page 5
5.0—Single Nitrous-Fuel Solenoid Installation	Page 6
5.1—Hold and Wait Style Progressive Timer	Page 6
5.2—Progressive Timer Reset with Activation Signal	Page 7
6.0—Multiple Nitrous-Fuel Solenoid Installation	Page 8
6.1—Hold and Wait Style Progressive Timer	Page 8
6.2—Progressive Timer Reset with Activation Signal	Page 9
7.0—Testing Controller Operation and Trouble Shooting	Page 10
8.0—Specifications	Page 11
9.0—Warranty	Page 11

1.0—Important Information - Must use Static Suppression Ignition Wires with this Controller. The NX #15835 Nitrous Controller contains High Frequency Digital Electronics and will NOT function correctly without Suppression Wires!

Caution - Do NOT submerge Controller in liquid or directly wash unit with liquid of any type! (Do NOT spray when washing vehicle!)

Warning - The Programming Switches are Delicate Electronic items and can be damaged by misuse and/or carelessness. If the Controller is close to your Nitrous Bottle be careful when installing the bottle. The weight of the bottle is enough to easily damage the switches. Switches that have been determined to be damaged due to neglect will NOT be covered under Warranty.

It is the responsibility of the purchaser to follow all guidelines and safety procedures supplied with this product and any other manufactures product used with this product. It is also the responsibility of the purchaser to determine compatibility of this device with the vehicle and other components.

Nitrous Express assumes no responsibility for damages resulting from accident, improper installation, misuse, abuse, improper operation, lack of reasonable care, or all previously stated reasons due to incompatibility with other manufacturer's products.

Nitrous Express assumes no responsibility or liability for damages incurred from the use of products manufactured or sold by Nitrous Express on vehicles used for competition racing. Nitrous Express neither recommends nor approves the use of products manufactured or sold by Nitrous Express on vehicles which may be driven on public highways or roads, and assumes no responsibility for damages incurred from such use.

It is the purchaser's responsibility to check the state and local laws pertaining to the use of Nitrous Oxide for racing applications. Nitrous Express does not recommend nor condone the use of its products for illegal street racing.



2.0—Controller Description and Basics of Operation

The NX #15385, Nitrous Controller was designed to be a cost effective and accurate controller for the Application of Nitrous Power. By using the latest technology a .0000025 second resolution timer system is available for precise control of the solenoids. The programming switches are simple to use and provide binary coded information to the 32Mhz Microcontroller. By using binary coded switches with positive detent positioning the user selected values will not change with system voltage and/or temperature changes. The switches are only read during a power on condition and any accidental changes will not be recognized during operation.

The activation input has been designed to provide a ground while the activation signal is OFF to provide compatibility with Timing Retard Activation Inputs of popular Ignition Systems.

The Starting Percent (initial power) is adjustable from 20% to 50% in 2% increments. When the activation signal is applied, the controller will activate the solenoids using the selecting starting percent of power. Note, if the build time switch is set to 0.0 the Nitrous will immediately go to full power regardless of the start percent setting.

The Build Time (Time in seconds to Full Power) is adjustable from 0.0 (Instant Full Power) to 8.0 seconds in 0.5 second increments. A short build time will apply the nitrous power much more aggressively than a long build time.

An internal 20 second Timer will begin when the activation signal is applied. After the 20 second timeout period the controller will wait 2 seconds before resetting the Progressive Timer. The activation signal Must be Removed to complete the Progressive Timer Reset.

The controller can be installed to provide Hold and Wait Timer Function or Reset Timer with Activation Signal.

The Hold and Wait method will remember where the Nitrous Power was at if the user lifts the throttle (removes the activation signal) and then Re-Applies it.

The Reset Timer method will Reset the controller every time the activation signal is removed and re-applied. This method allows the Nitrous Power ramp to be used with each gear change.

Note - that after the 20 second internal timer has elapsed the Nitrous Solenoids will be turned OFF. The activation signal must be removed after the 20 second timer has elapsed or the controller will continue to wait in an OFF condition. When the activation signal is removed all Timers are Reset and the controller is ready for operation again.

Instructions are provided for each method of installation as well as for Single and Multiple Solenoid installations.

Test Procedures and Trouble Shooting guides have been included. Please see the **Table of Contents** on Page 2 for further information.



3.0—Setting the Nitrous Power Ramp

Please refer to the following three sections for detailed information about Setting the Start percent and Build Time. These settings determine how aggressive the Nitrous Power is applied. There is an example Nitrous Power Ramp chart that shows how the Settings are applied by the controller.

3.1—Setting the Start Percent

Use the Nitrous Start Percent switch (left one) to select the desired amount of Nitrous Power. The range is 20% to 50 in 2% increments. Just set the Start Percent switch to the desired amount. The switch position will be read when power is applied to the controller. If the switch position is changed while the controller is on and/or activated the new setting will be ignored until the next time the controller is turned on.

3.2—Setting the Build Time

Use the Build Time in Seconds switch (right one) to select the desired amount of Time it takes for the controller to go from the Start Percent to Full Power. The range is 0.0(no build time, instant full power) to 8.0 in 0.5 second increments. Just set the Build Time switch to the desired time to full power. The switch position will be read when power is applied to the controller. If the switch position is changed while the controller is on and/or activated the new setting will be ignored until the next time the controller is turned on.

3.3—Example Nitrous Power Graph

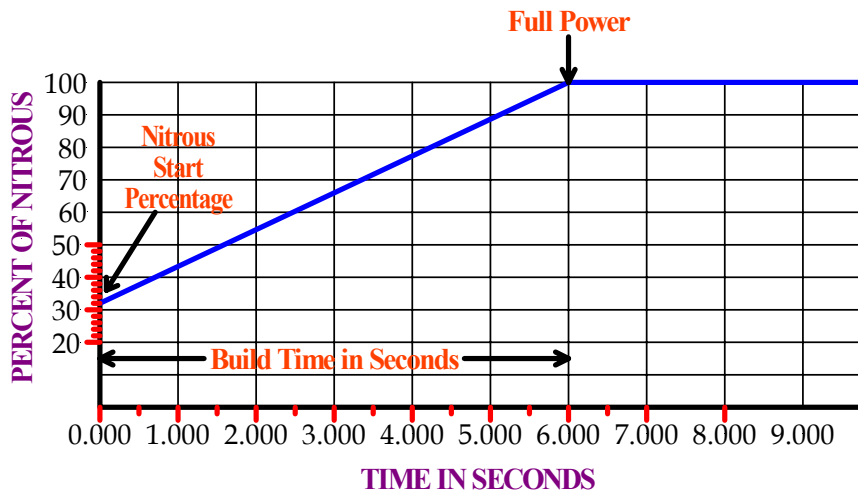

Range of Settings for NX #15835 are displayed in Red.

Settings for example graph would be,
Start Percent set at 32 percent
Build Time set at 6.0 seconds



4.0—Installation Basics

Items Included with the NX #15835 Controller

- 1 - Wiring Harness
- 4 - Installation & User Manual

Items needed that are NOT Supplied with Controller

- 1 - Nitrous Kit
- 2 - Safety Solenoid
- 3 - Activation Switches as needed, If not included with the nitrous kit.
- 4 - 40 Amp Relay, If not included with the nitrous kit.
- 4 - Static Suppression Ignition Wires

Cautions and Warnings

- 1 - Always follow Installation Guidelines and Safety Pre-cautions when installing this and any other related components.
- 2 - Remove battery Positive when installing new components and/or wiring.
- 3 - Install Ground Wire first, always connect before battery positive.
- 4 - Connect Ground wire Direct to Battery Negative Terminal and then to the Controller.
- 5 - Always use proper Circuit Protection where required (fuse, circuit breaker).
- 6 - Do NOT mount the NX #15835 controller in close proximity to Ignition Coils, Solenoids, or other High voltage-current devices.
- 6 - Always test system operation after installation to insure proper operation.
- 7 - Never Weld on vehicle with controller installed!
- 8 - Turn OFF all electronic devices before connecting, disconnecting a battery charger.

IMPORTANT - Must use Static Suppression Ignition Wires. Can NOT use any type of Metal Spiral Core and/or Metal Core Ignition Wires. Controller contains High Frequency Digital Circuitry and can NOT function properly with RFI or EMI Interference!



5.0—Single Nitrous-Fuel Solenoid Installation

5.1—Hold and Wait Style Progressive Timer

Note - The Red LED lamp should be on steady with Arming Switch ON and the Activation Signal OFF. LED Lamp will blink when +12V is applied to the Activation Terminal.



Timing Retard Activation

Note - The activation terminal has an integrated resistor to Ground. This is to insure that the Timing Retard Inputs of popular Ignitions are OFF when the Controller is NOT activated.

IMPORTANT - The Nitrous and Fuel Solenoid Grounds can be combined on either Output. This will generally richen the mixture slightly due to the Fuel Solenoid going to 100% sooner. This happens because of the large EMF Voltage produced by the higher amperage Nitrous Solenoid affecting the Fuel Solenoid Operation.

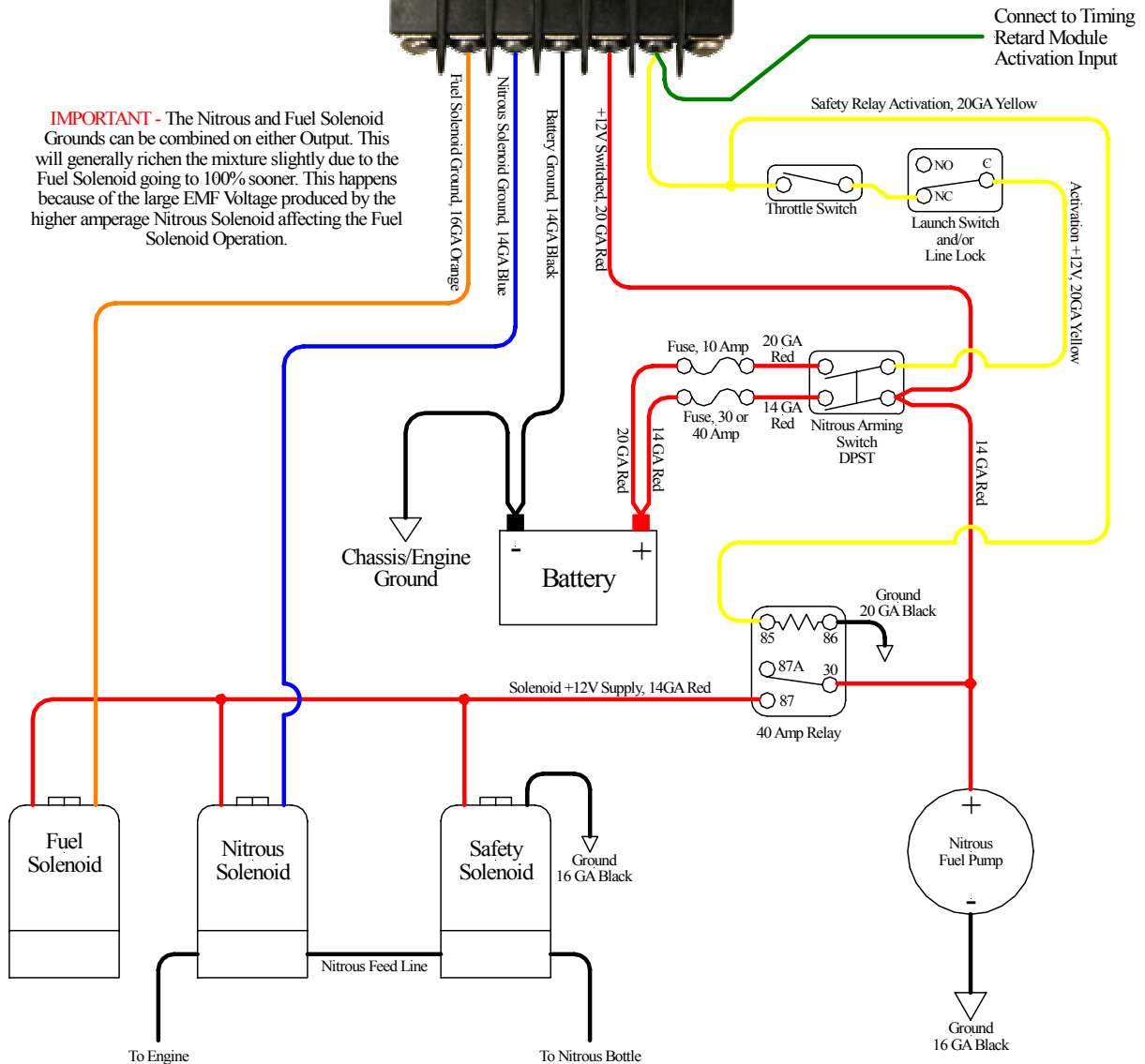



5.2—Progressive Timer Reset with Activation Signal

Note - The Red LED lamp should be OFF with Arming Switch ON and the Activation Signal OFF. LED Lamp will blink when +12V is applied to the Activation Terminal.



Timing Retard Activation

Note - The activation terminal has an integrated resistor to Ground. This is to insure that the Timing Retard Inputs of popular Ignitions are OFF when the Controller is NOT activated.

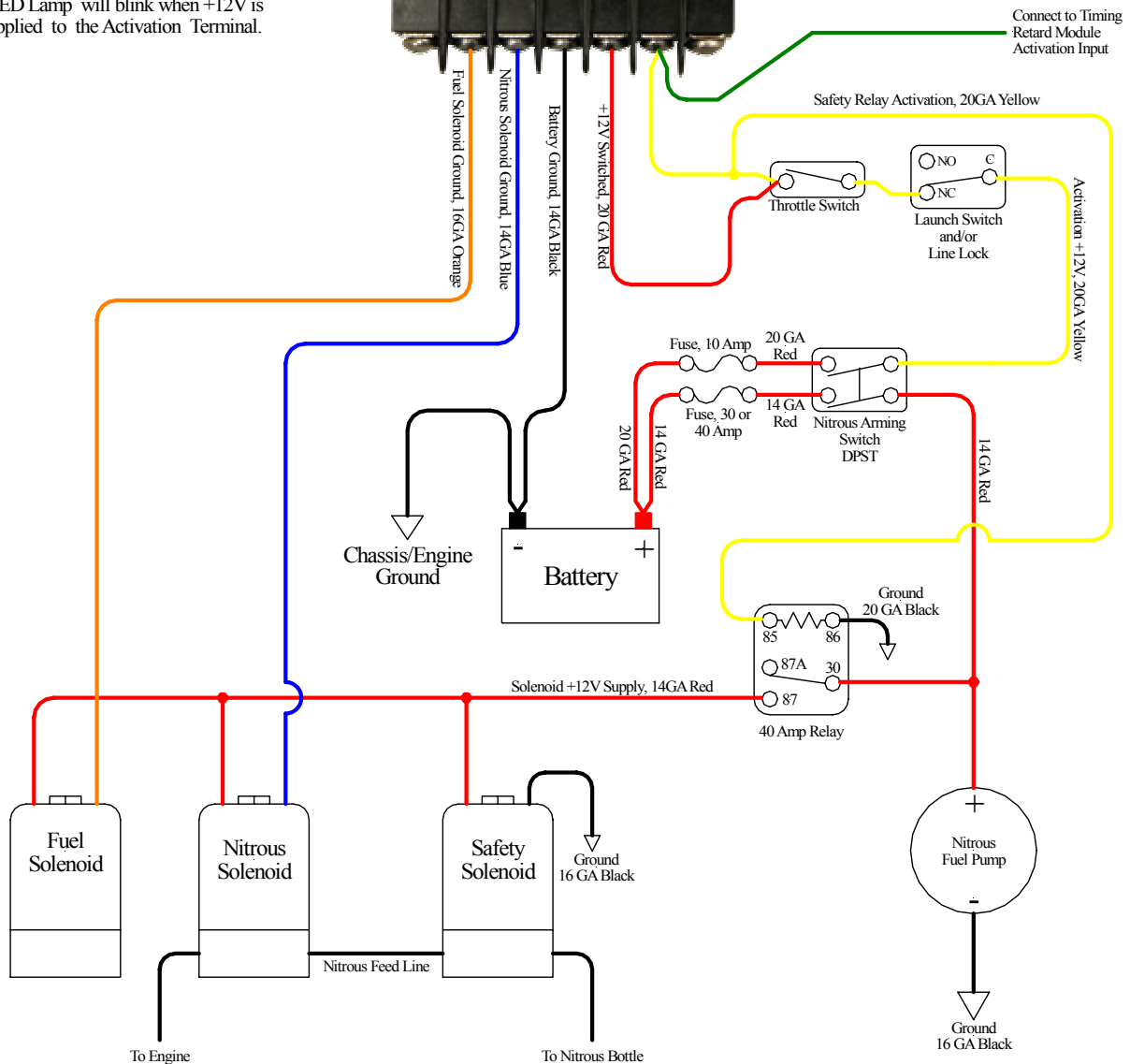



6.0—Multiple Nitrous-Fuel Solenoid Installation

6.1—Hold and Wait Style Progressive Timer

Note - The Red LED lamp should be on steady with Arming Switch ON and the Activation Signal OFF. LED Lamp will blink when +12V is applied to the Activation Terminal.



Timing Retard Activation

Note - The activation terminal has an integrated resistor to Ground. This is to insure that the Timing Retard Inputs of popular Ignitions are OFF when the Controller is NOT activated.

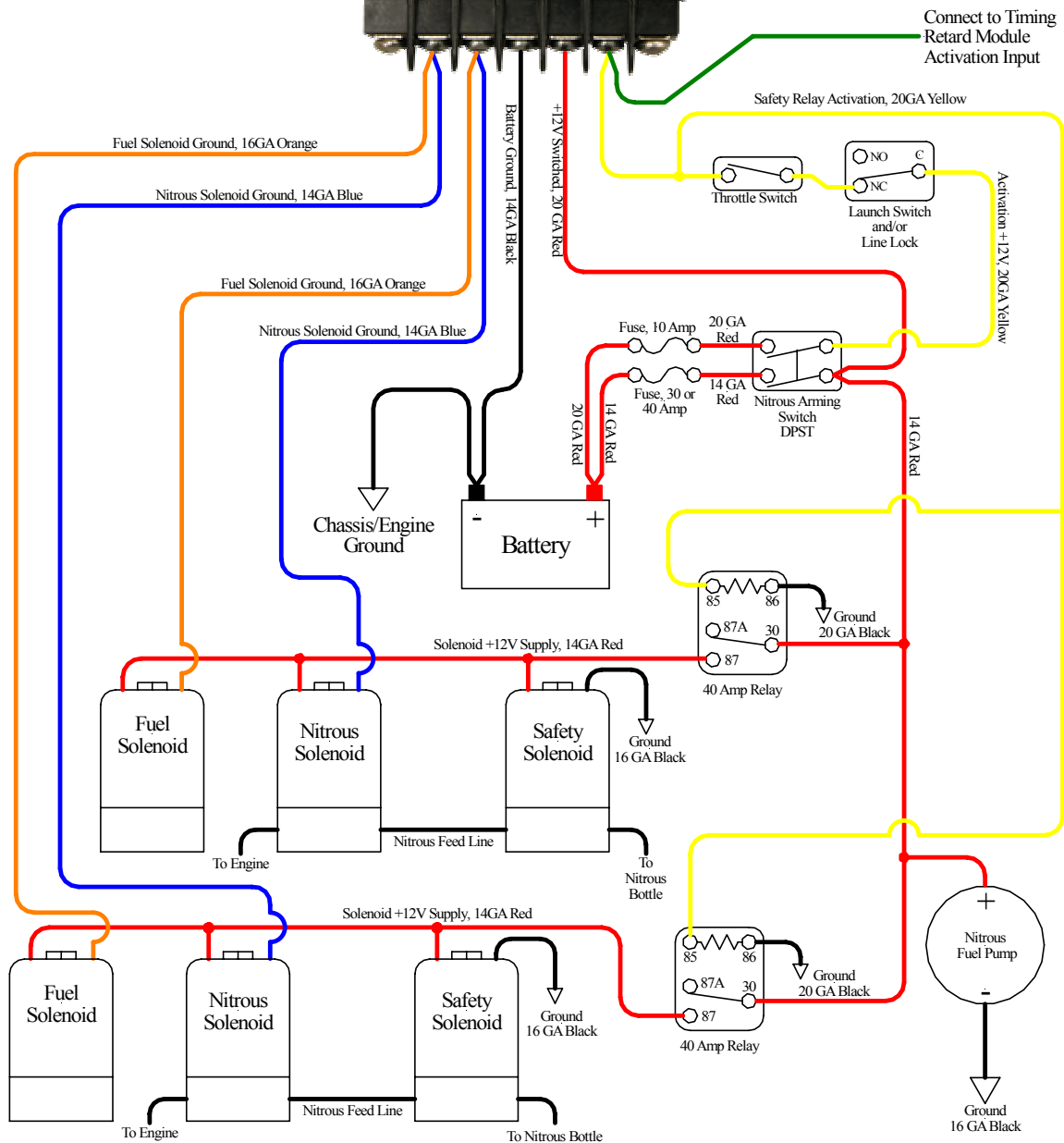



6.2—Progressive Timer Reset with Activation Signal

Note - The Red LED lamp should be OFF with Arming Switch ON and the Activation Signal OFF. LED Lamp will blink when +12V is applied to the Activation Terminal.



Timing Retard Activation
 Note - The activation terminal has an integrated resistor to Ground. This is to insure that the Timing Retard Inputs of popular Ignitions are OFF when the Controller is NOT activated.

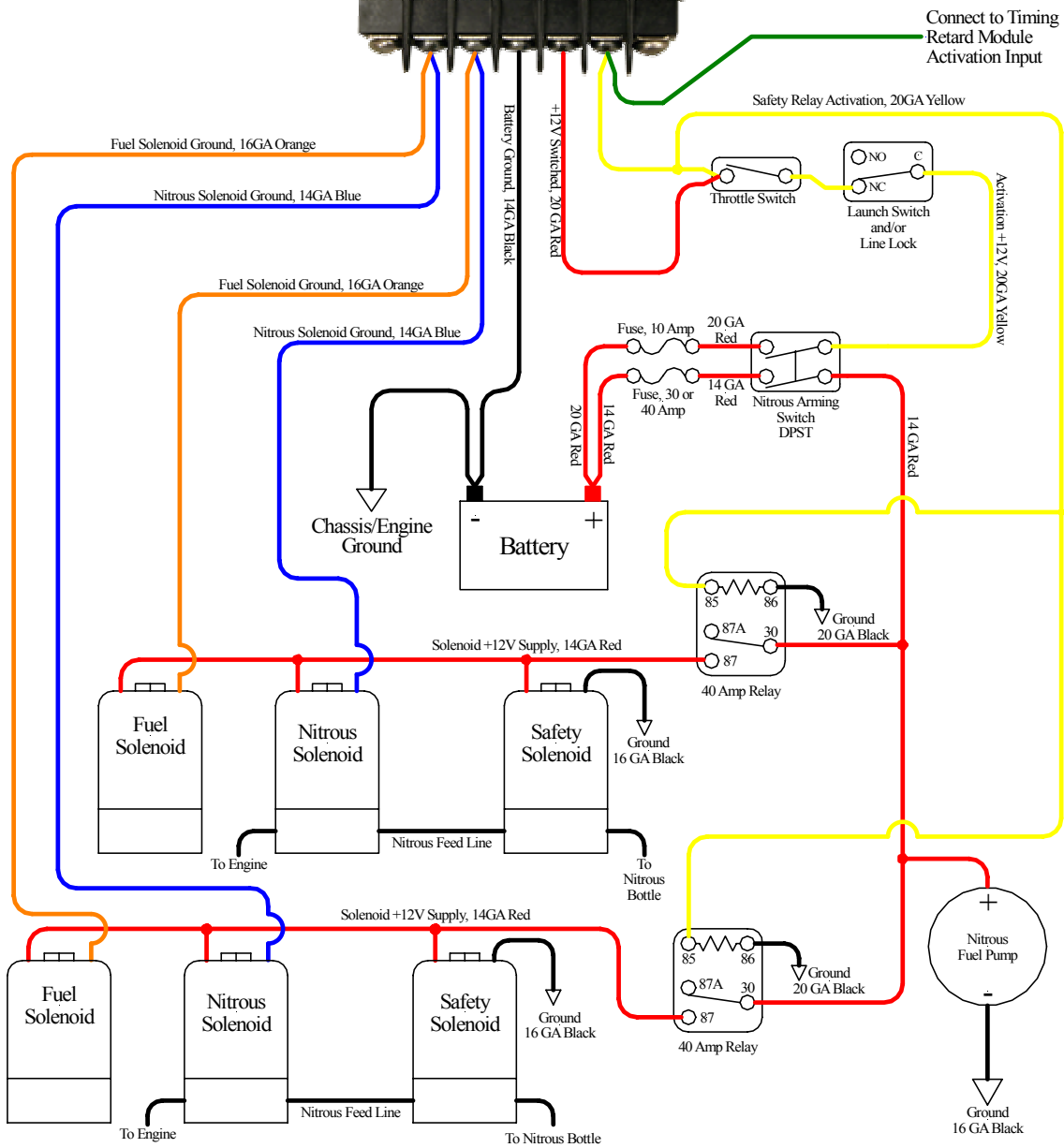



7.0—Testing Controller Operation and Trouble Shooting

The controller operation can be tested with the vehicle engine OFF, Nitrous Fuel Supply OFF, and the Nitrous Supply (bottle) OFF. Never test the system with Fuel and Nitrous Supply ON, this will fill the non-running engine and can be very destructive to engine components and personnel when it is started the next time!

After insuring that all supplies are OFF, turn On the Nitrous Arming Switch. Depress the Throttle (or activate throttle switch manually) to activate the controller. If the controller is set for 0.0 build time the solenoids should snap open immediately. Any other setting will pulsate the solenoids for the build time setting and then the solenoids will go to full power.

The Red LED Lamp will be on solid with the controller On and NOT activated. When the activation signal is applied the LED Lamp will blink. This can be used to check for proper activation signal.

If the controller has been installed for Hold and Wait Timer releasing the throttle switch will stop the solenoids. When the throttle switch is applied again the controller will resume at the point it was stopped at (provided the internal 20 second has not elapsed). If the internal 20 second timer has elapsed before the throttle is released the solenoids will be turned OFF until the activation signal is released and reapplied.

If the controller has been installed for Reset with Activation Signal releasing the throttle switch will turn off the controller and the solenoids. When the throttle switch is applied again the controller will begin the Nitrous Power Ramp from the start percent setting. If the internal 20 second timer has elapsed before the throttle is released the solenoids will be turned OFF until the activation signal is released and reapplied.

Trouble Shooting Incorrect Controller Operation.

1 - Engine Running Rich while using Progressive Nitrous

A - Starting Percentage to low for a given bottle pressure and solenoid combination (only fuel solenoid opening).

B - Fuel pressure to high for fuel solenoid to operate correctly when pulsating.

2 - Nitrous seems to Delay after Activation

A - Improper Nitrous Jetting, Fuel Jet to rich. Some vehicles will run rich with the Nitrous Controller installed due to the Fuel being slightly richer at low percentages.

B - Starting Percentage to low for a given bottle pressure and solenoid combination (only fuel solenoid opening).

3 - Nitrous Turns OFF during operation

A - To much current draw from solenoids. System fuse-circuit breaker may be overloaded. Controller will limit amperage to the solenoids if an over current condition is detected. See specifications for maximum ratings.

B - Electrical interference from Ignition System or other Electronic Device(s) causing the controller to lock up or turn off.



8.0—Specifications

Normal Operating Voltage	10.0 to 18.0 Volts, Negative Ground Controller will Turn OFF at 6.2 Volts
Solenoid Outputs	45 Amps Maximum each output
Activation Input	125mA at 12.0 Volts
Weight (approx)	.4 lb.
Overall Height	1.750 in.
Overall Width	3.125 in.
Overall Length	4.375 In.

9.0—Warranty

Nitrous Express warrants to the original purchaser that the components shall be free from defects in parts and workmanship under normal use for 6 months from the date of purchase.

Nitrous Express obligation under this warranty is limited to the repair or replacement of any NX #15835 component found to be defective when returned postpaid to Nitrous Express. The item must be returned with evidence of place and date of purchase or warranty will be void. The warranty will not apply to any component that has been used incorrectly, repaired, damaged, or tampered with by misuse, negligence or accident.