



Octane SERIES



3000 0%

PROGRESSIVE NITROUS CONTROLLER INSTALLATION AND USER MANUAL

**Nitrous Express Inc. 5411 Seymour Hwy Wichita Falls TX, 76310
tel 940.767.7694 fax 940.687.0751**

www.nitrousexpress.com

Table of Contents

Page

WHAT THE GAUGE CAN DO.....3

Basic Features:..... 3

Advanced Programming Features..... 3

Programming your Progressive Nitrous Controller.....4

STEP 1. SETTING UP PUP & ARM SCREENS. 4

STEP 2. ENABLE OR DISABLE HEATER..... 4

STEP 3. Configure Screen 5

STEP 4. Configure Inputs- RPM. 5

STEP 5. Configure Inputs- ARM. 6

STEP 6. Configure Inputs- TPS..... 7

STEP 6. Configure Inputs- Air/Fuel. 7

STEP 7. Configure Inputs- PRESSURE..... 9

STEP 8. SAFTEY Cutouts..... 10

STEP 9. HEATER Target 12

STEP 10. NITROUS Setup..... 13

STEP 11. NITROUS Ramp 15

Main Viewing Screens and ICON table..... 16

Wiring Diagram 17

Specifications..... 18

Warranty 18

WARNING

TO AVOID DAMAGING THE DISPLAY, NEVER PUSH ON THE SCREEN.

DO NOT PUSH ON THE SCREEN WHILE PLUGGING IN THE HARNESS, AS YOU WILL DAMAGE THE UNIT.

THE CONTROL BUTTON CAN ONLY BE MOVED UP, DOWN, AND INWARD. NONE OF THOSE DIRECTIONS IN COMBINATION FOR IT WILL DAMAGE THE GAUGE AND VOID THE WARRANTY

The Nitrous Express Progressive Nitrous Controller gauge will control many aspects of your nitrous system. This device is the world's first all-in-one full color controller with integrated display. No need for a Laptop computer or additional boxes, it's all in the 2-1/16th inch gauge. The Progressive Nitrous Controller combines microprocessor controls, with a real world color user interface. The base model gauge (PN: 15535) can do progressive nitrous, but you must purchase an additional driver for each additional pair of Nitrous/Fuel solenoids. (PN: 15536). You will be able to program the gauge in seconds once you read the instructions. Take the time and read all the instructions before beginning your installation. Failure or damage may occur if all the wiring and programming are not done properly.

WHAT THE GAUGE CAN DO

The Nitrous Express Progressive Nitrous Controller gauge can be used for many items that relate to the operation of your nitrous system.

Basic Features:

- RPM window switch
- Wide-Open-Throttle detection when used with factory TPS or WOT switch. (Supports Fly-by-wire TPS)
- Progressive controller (time or RPM based) with a 5 section programmable ramp

BUT IT ALSO CAN BE A COLOR:

- Progressive Controller Monitor Gauge which graphically displays all configured options
- AIR/FUEL Gauge that supports all O2 widebands with a programmable analog output or the FJO Digital Data Bus.)
- Nitrous Pressure Gauge with programmable safety set points.
- Boost Gauge with programmable safety set points.
- Fuel Pressure Gauge with programmable safety set points.
- Oil Pressure Gauge with programmable safety set points.
- Automatic Bottle Heater Control with safety shut-off
- Shift Light

Advanced Programming Features

- Lean and Rich Cut-Off
- Remote ARming
- First Gear Lockout
- Ramp delay
- Default Power Up display mode
- Automatic Armed display mode
- User defined color ranges for each configured option
- Expandable progressive driver that allows the main unit to drive an unlimited number of solenoids

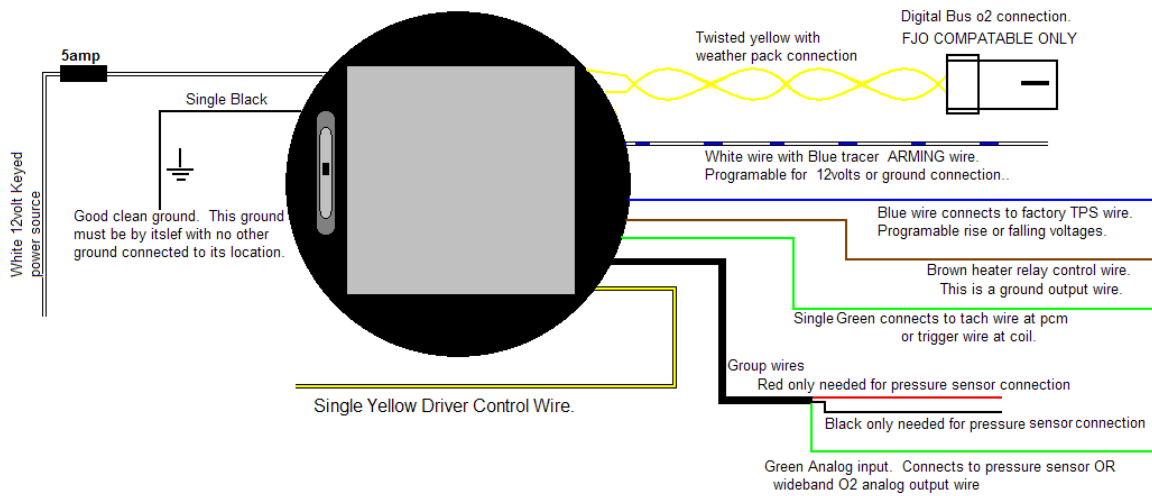

DO NOT PUSH ON THE SCREEN WHILE PLUGGING IN THE HARNESS, AS YOU WILL DAMAGE THE UNIT.

Programming your Progressive Nitrous Controller.

STEP 1. SETTING UP PUP & ARM SCREENS.

Exit
Enable Heater
Configure
Set PUP screen
Set ARM screen
Slide Show

After properly wiring your gauge turn the power on. You will see a couple of splash screens come up and then you will see the first viewing screen or PUP screen. PUP screen is your *Power UP* screen, and can be adjusted and saved to fit your viewing needs. (You will be able to view other screens by toggling the programming button on the side of your display.) You have 8 choices to choose from for your PUP screen, and ARM screen. The ARM screen comes up automatically when the Gauge is armed.

Toggle the control button up to scroll through the VIEWING screens until you find the one you want to see while driving your car, and one you want to see when your arming switch is on. Scroll to the display you like for your PUP screen and push the Control button in. You will now see the Main-programming menu. Toggle down until Set PUP Screen is highlighted and push the control button. The PUP screen is now saved and you will return to the main display.

Exit
Enable Heater
Configure
Set PUP screen
Set ARM screen
Slide Show

Toggle Down to
Set PUP screen
Push Control button in,
your PUP screen is now
saved.

Exit
Enable Heater
Configure
Set PUP screen
Set ARM screen
Slide Show

Toggle Down to
Set ARM screen
Push Control button in,
your ARM screen is now
saved.

Now scroll to the display you like for your ARM screen and repeat the steps for the PUP except this time you select Set ARM screen.

STEP 2. ENABLE OR DISABLE HEATER.

From the main viewing screen push the control button in.

At the Main Programming screen, scroll down to the enable or disable heater control field. Pushing the control button in will change this option and automatically returns to the Main Programming screen.

Exit
Disable Heater
Configure
Set PUP screen
Set ARM screen
Slide Show

You will need the 1600psi sensor or pn-SHP1500 for this option to work.

Exit
Enable Heater
Configure
Set PUP screen
Set ARM screen
Slide Show

STEP 3. Configure Screen

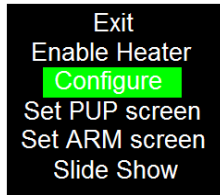

Push the control button to enter the Configure Screen.

Select Configure and push the control button to enter the configuration menu

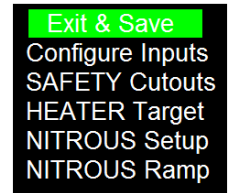

STEP 4. Configure Inputs- RPM.

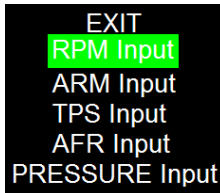

Starting from the Exit & Save menu shown above, toggle the control button down until RPM Input, is highlighted.

Push the control button in and you will this screen. Scroll down one space.

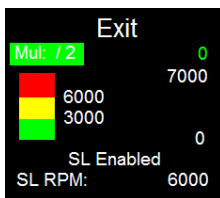
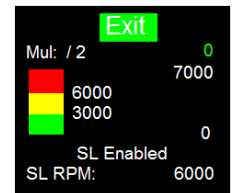

This is the Multiplier for your RPM signal. Push the control button in and the screen toggles to grey so you can adjust the multiplier up or down. Since this gauge can work with many different electronic ignitions this may need to be adjusted up or down for your application. If connecting to a true tach signal you would divide by the number of cylinders by 2. For an 8 cyl your Mult: would be 4. The number to the far RIGHT is what your gauge thinks your real RPM is. If you are at 2000RPM and this read out does not match, you will need to make adjustments to the Mul: section. EXAMPLE: If you are at 2000RPM and the gauge shows 4000 you need to double the multiplier. Once you make that correction the number should match your tach. Keep in mind that most analog tachs are a little off, so if you are at 2000 and the gauge shows 2050 you're fine! Push the control button in and the multiplier is saved.

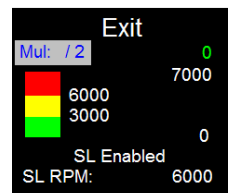

SCROLL Down:

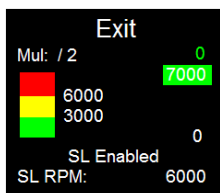

This is your HI side range for the tach. The closer you keep this number to your red line works nicely. Push the control button in and it turns to grey allowing you to make adjustments. Push the control button up or down to increase or decrease the value. When you get to the desired RPM, push the control button in to save it. This number is for the resolution of your tach scaling only, nothing more.

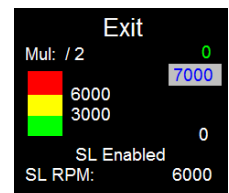

SCROLL Down:

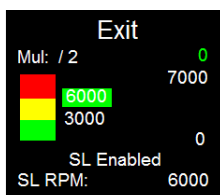

This is the HI change color. The displayed RPM will change from yellow to red above this point. Push the control button and it will turn grey and you can make your adjustments. Push the control button again to save it.

SCROLL Down:

This is the LOW change color. Your gauges RPM numbers will change from green to yellow at this point. Push the control button and it will turn grey and you can make your adjustments as needed. Push the control button again to save it.

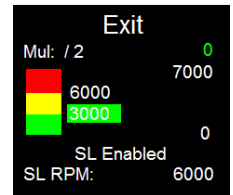

SCROLL DOWN:

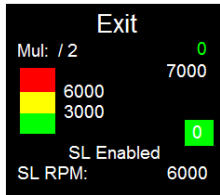

This is your LOW side range for the tach. To change this number up or down push the control button and it turns to grey allowing you to change the value. Push the control button when you get to the desired RPM. Again, this number is for the resolution of your tach scaling only, nothing more. A typical setting would be 500RPM below your idle. Push the control button to save.

SCROLL DOWN:

This is your Shift Light Enable or Disable. Push the control button and it will toggle this setting.

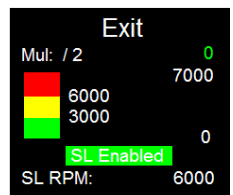

SCROLL DOWN:

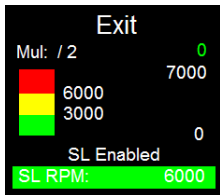

This is the Shift Light RPM. Your gauge is the shift light. The entire screen will jump to a solid color telling you it is time to shift. Pushing the control button will toggle the color to grey. Make your adjustment to up or down to fit your needs. This is the RPM point your shift light will come on. Push the button again.

SCROLL DOWN:

You have finished programming the RPM input for your gauge. Push the control button in again and you will EXIT the RPM input menu and return to the INPUT main menu.



STEP 5. Configure Inputs- ARM.

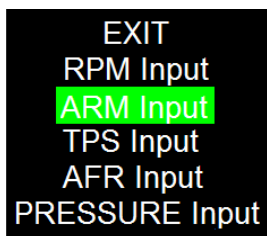

With ARM highlighted, push the control button and you will enter the ARM input menu.

In this menu you set the gauge to arm if you are triggering your nitrous system with a positive +12v source trigger.

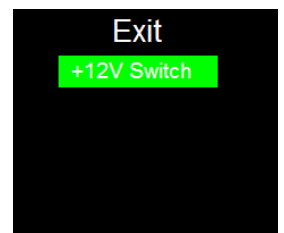

STEP 6. Configure Inputs- TPS.

When TPS Input is highlighted, push the control button and you will enter the TPS input menu.

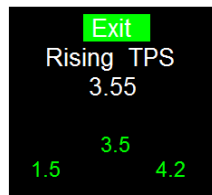
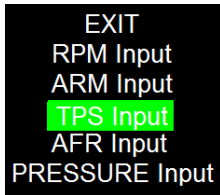

SCROLL DOWN:

This sets how the TPS function works. Rising means WOT is above the set point and Falling means it is below. Highlight *Rising* or *Falling* TPS and push the control button to toggle the setting.

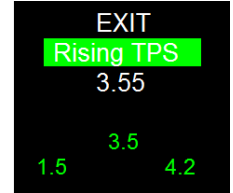

SCROLL DOWN:

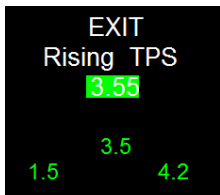

The highlighted number show is the Wide-Open-Throttle setting.

The number to the lower left is the lowest voltage the TPS locked in on, the center number is the voltage the TPS is at presently, and the lower right is the highest voltage the TPS has locked in on. Pushing the control button will toggle the color to grey and allow you to change the value. Push the control button in to save. Scroll to exit and push the control button to return you to the INPUT main menu.

STEP 6. Configure Inputs- Air/Fuel.

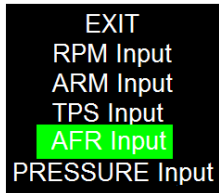

With AFR Input highlighted, push the control button and you will enter the AFR input menu.

SCROLL DOWN:

The first line sets the O2 input type. Digital selects the FJO Digital Data Bus as the AFR input – only for use with the FJO Gen-3 wideband. Analog is for all other widebands, and NONE tells the PNC that no wideband is connected. To change this setting, push the control button in. The area will go grey, and you can toggle up or down to the desired input type.

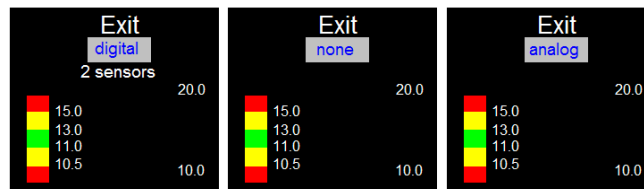

Push the control button in to save the setting.

NOTE: The analog setting requires that your wideband output curve is linear [10AFR=0.5v / 20AFR=4.5v]

SCROLL DOWN:

If you selected digital you must use the FJO GEN-3 wideband. Because this setting allows you to have up to 8 FJO widebands on the digital data bus, you must tell the controller how many it should look for. If it does not find them, or if one of them fails during operation, it will report an error. The Analog option only supports one wideband so this line will only be present when set to digital.

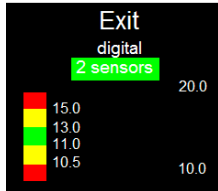

Push the button in the area will turn grey, and scroll up or down to the correct value. Push the control button in to save the value.

SCROLL DOWN:

This is the HI side set point for your wide-band scale. The closer this number is to your highest number the finer the scale will be. Pushing the control button in will turn the area grey and now you can scroll up or down to the correct value.

Push the control button in again to save.

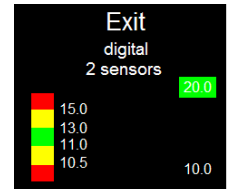

SCROLL DOWN:

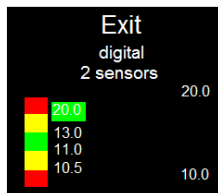

This is the HI side set point where your air fuel display will change from yellow to red. Pushing the control button in will turn the area grey and now you can scroll up or down to the correct value. Push the control button in again to save.

SCROLL DOWN:

This is the MID/HI side set point where your air fuel display will change from green to yellow. Pushing the control button in will turn the area grey and now you can scroll up or down to the correct value. Push the control button in again to save.

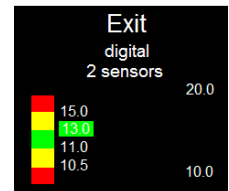

SCROLL DOWN:

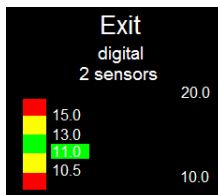

This is the low/mid side set point where your air fuel display will change from yellow to green. Pushing the control button in will turn the area grey and now you can scroll up or down to the correct value. Push the control button in again to save.

SCROLL DOWN:

This is the low side set where your air fuel display will change from red to yellow. Pushing the control button in will turn the area grey and now you can scroll up or down to the correct value. Push the control button in again to save.

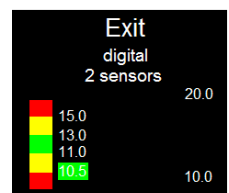

SCROLL DOWN:

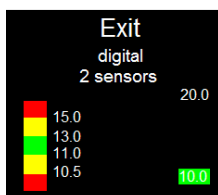

This is the low side set point for your wide-band scaling. The closer this number is to your low number the finer the scale will be. Pushing the control button in will turn the area grey and now you can scroll up or down to the correct value. Push the control button in again to save.

SCROLL DOWN:

Push the control button in again to Exit the air fuel input screen and return to the Main input screen.

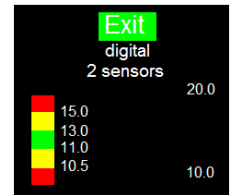

STEP 7. Configure Inputs- PRESSURE.

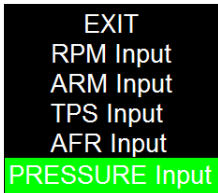

Push the control button in and you will see this screen.

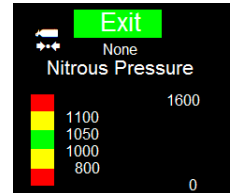

SCROLL DOWN:

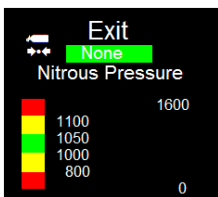

Pushing the control button in will turn the area grey and now you can scroll up or down to find the proper PSI sensor setting. Your choices are 15psi, 50psi, 100psi, 200psi, 1500psi and, 1600psi. Once you have chosen the proper sensor push the control button in to save.

SCROLL DOWN:

Pushing the control button in will turn the area grey and now you can scroll up or down to find the proper type for your psi sensor setting. Your choices are Nitrous, Boost, Fuel, or Oil. Once you have the correct setting, push the control button in to save.

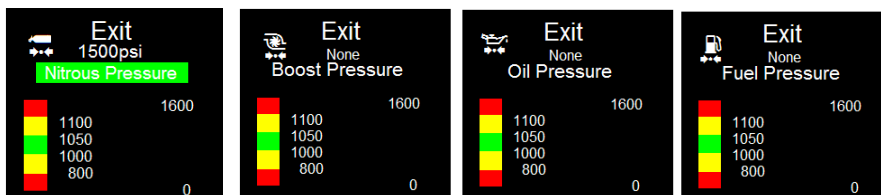

Take note of the ICON in the upper left corner, as these will be used as labels on the main viewing screen.

SCROLL DOWN:

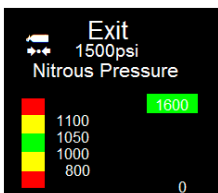

This is the HI side number used for scaling. The closer this number is to your highest number the finer the scale will be. Pushing the control button in will turn the area grey and now you can scroll up or down to the correct value. Push the control button in again to save.

SCROLL DOWN:

This is the HI side set point where your pressure display will change from yellow to red. Pushing the control button in will turn the area grey and now you can scroll up or down to the correct value. Push the control button in again to save.

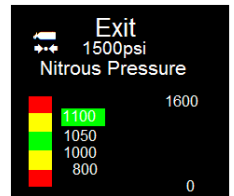

SCROLL DOWN:

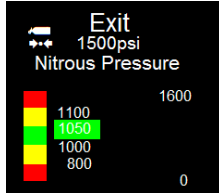

This is the mid/ hi side set point where your pressure display will change from green to yellow. Pushing the control button in will turn the area grey and now you can scroll up or down to the correct value. Push the control button in again to save.

SCROLL DOWN:

This is the low/mid side set point where your pressure display will change from yellow to green. Pushing the control button in will turn the area grey and now you can scroll up or down to the correct value. Push the control button in again to save.

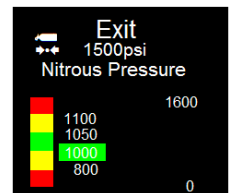

SCROLL DOWN:

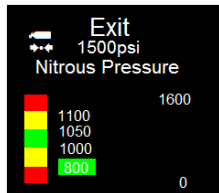

This is the low side set point where your pressure display will change from red to yellow. Pushing the control button in will turn the area grey and now you can scroll up or down to the correct value. Push the control button in again to save.

SCROLL DOWN:

This is the low side set point for your pressure scaling. The closer this number is to your low number the finer the scale will be. Pushing the control button in will turn the area grey and now you can scroll up or down to the correct value. Push the control button in again to save.

SCROLL DOWN:

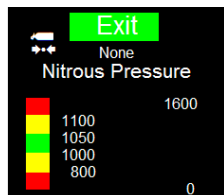

Push the control button in to save. You have programmed your PRESSURE Inputs and have returned to the INPUT main screen. Highlight Exit and push the control button in.

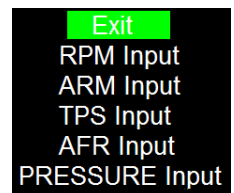

STEP 8. SAFTEY Cutouts

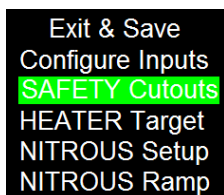

Push control button in and enter the SAFETY Cutouts screen.

SCROLL DOWN:

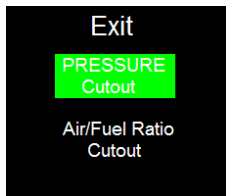

Push control button in and enter the PRESSURE Cutout screen.

SCROLL DOWN:

Push the control button in to toggle between enabled or disabled to fit your needs.

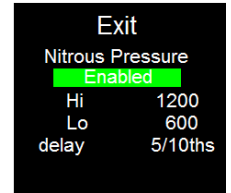

SCROLL DOWN:

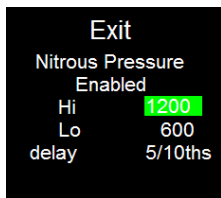

This is the HI side limit of your cutoff; the output will shut down if you exceed this pressure. Pushing the control button in will turn the area grey and now you can scroll up or down to the correct value. Push the control button in again to save.

SCROLL DOWN:

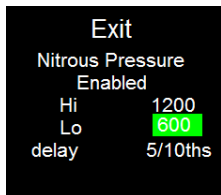

This is the Lo side limit of your cutoff; the output will shut down if you drop below this pressure. Pushing the control button in will turn the area grey and now you can scroll up or down to the correct value. Push the control button in again to save.

SCROLL DOWN:

This is the delay before cutout will happen. Pushing the control button in will turn the area grey and now you can scroll up or down to the correct value. Push the control button in again to save. Make your adjustments from 0 to 1 second.

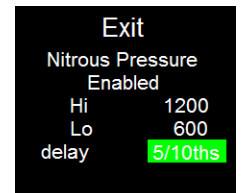

SCROLL DOWN:

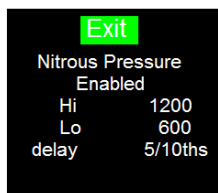

Push the control button in to save.

SCROLL DOWN:

Push control button in to enter the Air/Fuel Ratio Cutout screen.

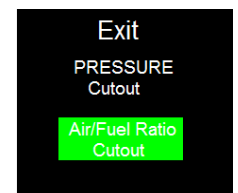

SCROLL DOWN:

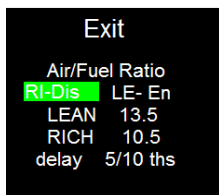

This setting enables or disables the rich side cutout only. You can toggle the setting by pushing the control button while it is highlighted.

SCROLL DOWN:

This setting enables or disables the lean side cutout only. You can toggle the setting by pushing the control button while it is highlighted.

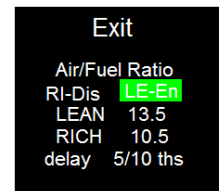

SCROLL DOWN:

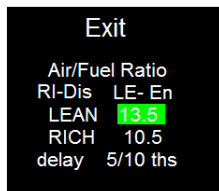

This is your lean threshold for the cutout. If you have ENABLED the lean cutout, the output will shut down if you go leaner than this setting. Pushing the control button in will turn the area grey and you can scroll up or down to the correct value. Push the control button in again to save.

SCROLL DOWN:

This is your rich threshold for the cutout. If you have ENABLED the rich cutout, the output will shut down if you go richer than this setting. Pushing the control button in will turn the area grey and you can scroll up or down to the correct value. Push the control button in again to save.

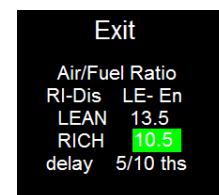

SCROLL DOWN:

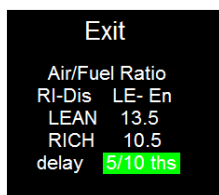

This sets the time that either the lean or rich condition must exist for before a cutout will happen. Pushing the control button in will turn the area grey and you can scroll up or down to the correct value. Push the control button in again to save. [0 – 1 sec]

SCROLL DOWN:

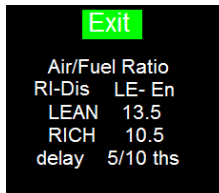

Push the control button in to save.

Push the control button in again to exit.

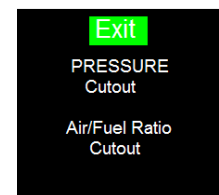

STEP 9. HEATER Target

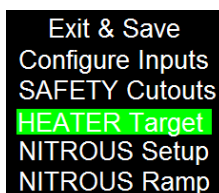

Push control button in and enter the HEATER Target screen.

SCROLL DOWN:



This is your target pressure for your bottle heater. The heater will turn off above this setting. It also has a safety that disables the heater if the pressure did not rise after 15 mins or if the pressure drops too low. Pushing the control button in will turn the area grey and you can scroll up or down to the correct value. Push the control button in again to save.



SCROLL DOWN:

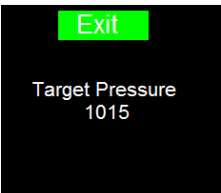

Push the control button in to save.

STEP 10. NITROUS Setup

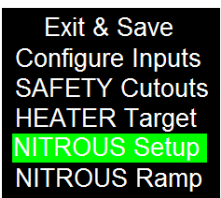

Push the control button in to enter the NITROUS Setup screen

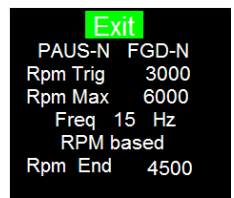

SCROLL DOWN:

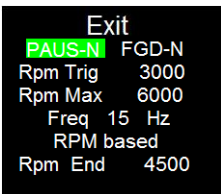

This is the ramp reset/resume option. This tells the gauge to either resume your ramp [PAUS-Y] or reset to beginning [PAUS-N]. EXAMPLE: while ramping you lift off the gas and then step back into it, you can either have the ramp continue where you left off or restart from the beginning. You can toggle the setting by pushing the control button while it is highlighted.

SCROLL DOWN:

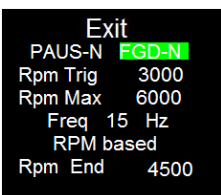

This is the First Gear Delay. Enabling this feature in RPM based mode will prevent the nitrous from activating until the first time your RPM exceeds Rpm Max [first gear lockout]. In Time based mode, it delays the nitrous from activating for set delay time or until the your RPM exceeds Rpm Max, which ever comes first. Once you have exceeded Rpm Max, the delay time is ignored until the gauge is either reset or re-armed. You can toggle the setting by pushing the control button while it is highlighted.

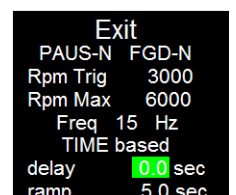

SCROLL DOWN:

```
Exit
PAUS-N FGD-N
Rpm Trig 3000
Rpm Max 6000
Freq 15 Hz
RPM based
Rpm End 4500
```

This is the start of your RPM window where the gauge will start the nitrous activation. (if all other conditions are met). Pushing the control button in will turn the area grey and you can scroll up or down to the correct value. Push the control button in again to save.

SCROLL DOWN:

This is the end of your RPM window, above which the gauge will stop the nitrous activation. Pushing the control button in will turn the area grey and you can scroll up or down to the correct value. Push the control button in again to save.

```
Exit
PAUS-N FGD-N
Rpm Trig 3000
Rpm Max 6000
Freq 15 Hz
RPM based
Rpm End 4500
```

SCROLL DOWN:

```
Exit
PAUS-N FGD-N
Rpm Trig 3000
Rpm Max 6000
Freq 15 Hz
RPM based
Rpm End 4500
```

This is the solenoid frequency. It sets is how many times/second your solenoids will be pulsed. 15Hz is a good number to start with. Small solenoids may be able to handle a higher setting. When in doubt, consult the solenoid manufacturer. Pushing the control button in will turn the area grey and you can scroll up or down to the correct value. Push the control button in again to save.

SCROLL DOWN:

This sets how the nitrous ramp is set [N2O vs.TIME or N2O vs. RPM] You can toggle the setting by pushing the control button while it is highlighted.

```
Exit
PAUS-N FGD-N
Rpm Trig 3000
Rpm Max 6000
Freq 15 Hz
RPM based
Rpm End 4500
```

SCROLL DOWN:

```
Exit
PAUS-N FGD-N
Rpm Trig 3000
Rpm Max 6000
Freq 15 Hz
RPM based
Rpm End 4500
```

This is the end point of the RPM based nitrous ramp [RPM based mode only]. **THIS IS NOT WHEN THE NITROUS TURNS OFF** it just allows you expand the resolution of the ramp. The system will continue to pulse the solenoids until Rpm Max is reached, using the rate set at the end of the user configured ramp. Pushing the control button in will turn the area grey and you can scroll up or down to the correct value. Push the control button in again to save.

SCROLL DOWN:

This is how much time the nitrous will be delayed by once all conditions for activation are met. IF you have FGD set to Y, and you exceed Rpm Max, the delay will be ignored until you either reset the gauge or re-arm it. This allows you to set a delay that is only active in first gear. Pushing the control button in will turn the area grey and you can scroll up or down to the correct value. Push the control button in again to save.

```
Exit
PAUS-N FGD-N
Rpm Trig 3000
Rpm Max 6000
Freq 15 Hz
TIME based
delay 0.0 sec
ramp 5.0 sec
```

SCROLL DOWN:

```
Exit
PAUS-N FGD-N
Rpm Trig 3000
Rpm Max 6000
Freq 15 Hz
TIME based
delay 0.0 sec
ramp 5.0 sec
```

This is the time the ramp takes to reach its final setting, also referred to as build time. Pushing the control button in will turn the area grey and you can scroll up or down to the correct value. Push the control button in again to save.

SCROLL DOWN:

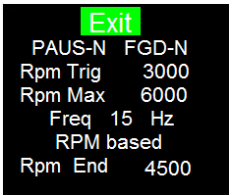

Highlight EXIT and push the control button to save and exit.

STEP 11. NITROUS Ramp

The PNC nitrous ramp is a curve that can be set by 6 user configurable points. You can ramp up, down or any combination all within the same curve.



Push the control button to enter the NITROUS Ramp screen.

This is your “progressive ramp” editing screen. The point being edited is highlighted in green and the corresponding percentage is displayed in green. The numbers to the left and right are your start & end time for time based mode, and Rpm Trigger & Rpm End for Rpm based mode. Pushing the control button up or down will move the highlighted GREEN dot. To save the current and edit the next dot, push the control button in.

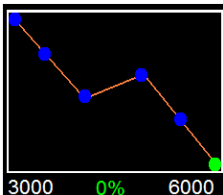
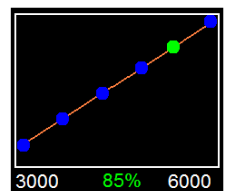
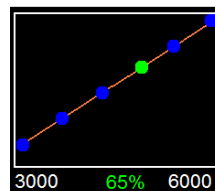
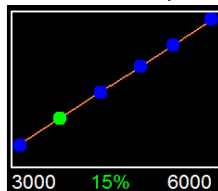
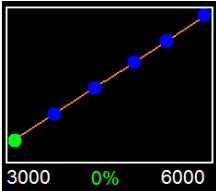

This is an example of reverse ramping for boosted cars.

Once you see this screen, push the control button in and all settings will be saved.

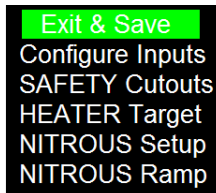

Main Viewing Screens and ICON table

These are your Main Viewing Screens. You can program any of these screens to be your PUP Screen or ARM Screen. The color RED is used through out the gauge and means that item is out or your preset parameters.

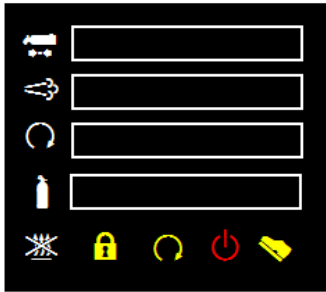

Complete Bar



Complete Number

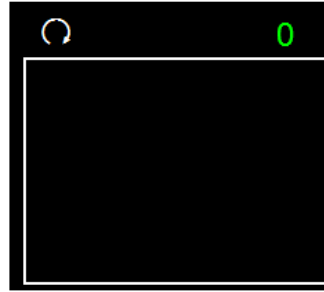

RPM Only

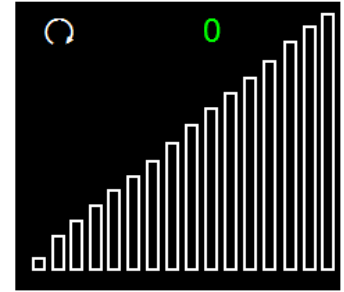

RPM Bar

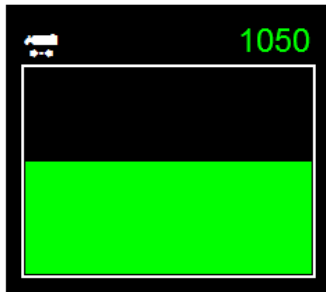

Pressure Only

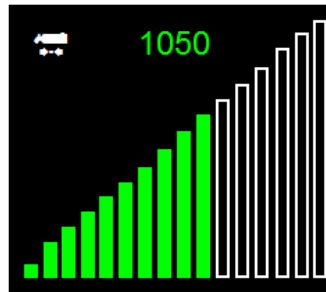

Pressure Bar



Air/Fuel Only

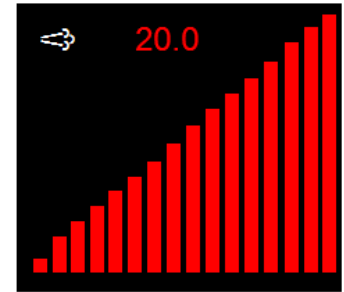

Air/Fuel Bar

- = Fuel Pressure
- | Progressive Amount
- 9 Boost Pressure
- q Boost Pressure
- . Oil Pressure
- % WOT Active or In-Active
- N First Gear Unlocked or Delay OFF
- M First Gear Locked or Delay On
- F RPM
- # Heater ON when red, Heater OFF when grey
- \$ Heater OFF, problem with heater system
- u Air / Fuel

Pressure Bar graph. This will show you the pressure you have selected to display. This area will change colors to match to programmed settings.

Air/ Fuel Ratio. If programmed for and the Wide band is turned on this area will change its colors to match your programmed ranges.

RPM / Tach. This displays the tach signal. Changes its colors to match your programmed ranges.

Progressive: This shows the programmed ramp in a bar graph form.

Heater on or off

First gear lock/delay feature on or off

The RPM Icon lets you know if you are in, above or below your settings.

Armed or Disarmed

WOT yes or no

Wiring Diagram

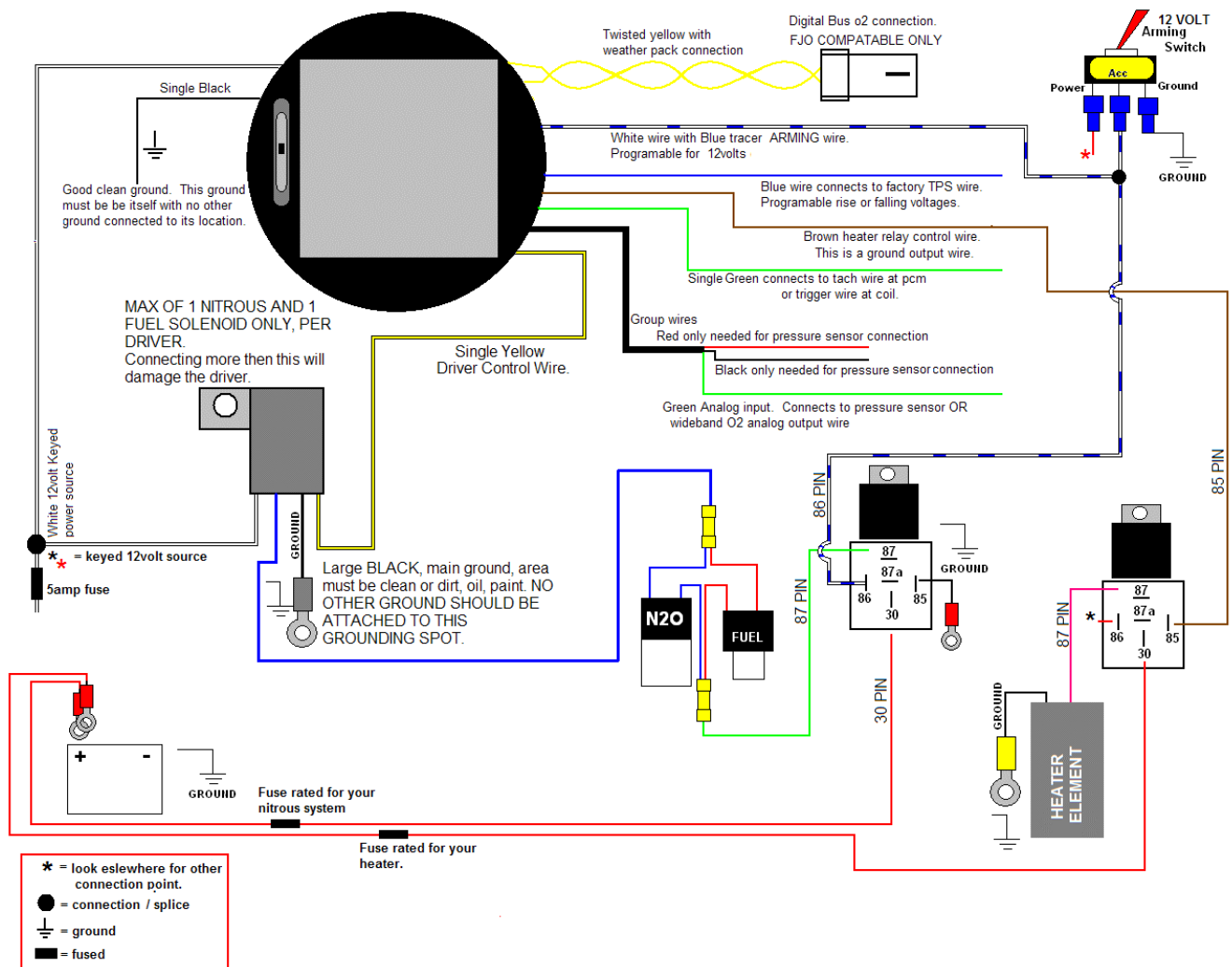

Moving from place to place in your gauge, programming tips & warnings!!!

Here are some tips for moving around and reprogramming your gauge.

- On the main viewing screen, push the control button up will change your screen to different views. This allows you to watch your sensors as just like it's another gauge. EXP. While tuning N/A you could watch air/fuel as if your Progressive Controller was just an air/fuel gauge. (sensor must be programmed and plugged into an Air/Fuel source).
- On the main viewing screen, push the control button down and your gauge will dim. Helpful when driving at night to lesson the brightness of your Progressive Controller. Push down again to return to bright.
- You do not have to go through each programming screen just to program 1 screen. You can enter configure mode and can jump to which ever mode you need to adjust. Same goes within a configure mode you can jump to the parameter you want to adjust. When finish just exit out then Exit/Save and you are done.
- Your heaters default mode is disabled. You will always need to enable your heater for it to work and heat your bottle, when you power down your gauge the heater will turn off.
- You may see some coloration though the bar graph areas. This is called banding and is normal and will not hurt the gauge in any way.
- When you have a cutout trip you will see a large RED area around the area that caused the trip. You will need to push the control button in, to reset this feature. This allows you to see what caused the nitrous system to turn off.
- Throughout your programming the term scaling is used. This deals with the bar under your numerical readouts.
- Make sure the ground wire to the Progressive Controller is by itself on a good clean area, (meaning no other wires are connected to it or in the general area). Especially hi amp cycling wires like solenoids etc.
- **NEVER PUSH ON THE SCREEN WHEN INSERTING ELECTRICAL SOCKET, DAMAGE TO THE SCREEN WILL HAPPEN.**
- **NEVER CONNECT THE POWER AND GROUND BACKWARDS. THIS WILL FRY YOUR GAUGE.**

Specifications

Power	10~18 volts dc
Physical Dimensions	2 1/16 th inch diameter by 2 1/2 inch deep [fits standard gauge pod or cup]
Display Dimension	1 1/8 th by 1 1/8 th inches
Relay Control Output Current	1 Amp max.
Sensor Inputs	5-volt max.
Weight	3 ounces [gauge only]

Warranty

DISCLAIMER:

Nitrous Express Inc. may not be held responsible for any damages, how so ever caused, to any persons or equipment during the installation and or operation of this product. Nitrous Express Inc. are meant for OFF-ROAD use only, and make no claims as to this products ability to meet local safety or emissions laws.

WARRANTY:

Nitrous Express Inc. warrants the material and workmanship of the equipment, components and parts manufactured by Nitrous Express Inc. against defects under normal use and service. This warranty shall extend for 90 days from the date of purchase provided that the customer first returns the defective part or component through an authorized dealer, shipping costs prepaid. Prior to returning a product for warranty inspection, the customer must contact Nitrous Express Inc. service department with the product serial number to receive a WARRANTY CLAIM NUMBER. Units returned without this number will be delayed or refused.

Nitrous Express Inc. may at its option, repair or replace without cost for parts and labor, the defective product. This warranty does not cover finishes, normal wear and tear, nor does it cover damage resulting from accident, misuse, dirt, tampering, unreasonable use, service attempted or performed by unauthorized service agencies, ACTS of Devine intervention, failure to provide reasonable maintenance, or that have been modified or used for commercial reasons.

Nitrous Express Inc. specifically does not warrant equipment, parts or components purchased by Nitrous Express Inc. or the customer from any third party manufacturers or suppliers. Rather, for and defect equipment, parts and components purchased from third party manufacturers or suppliers, the customer shall have a recourse only to the terms of the warranty of that particular manufacturer or supplier. Any recommendations made by the third party manufacturer or suppliers concerning the use or application of their products are those of the manufacturer or suppliers, and Nitrous Express Inc. extends no warranty with respect to the results obtained for their use. Nitrous Express Inc. does not warranty those products in any way beyond the tern of the warranty extended by the manufacturer or supplier.

The warranty provided above, Nitrous Express Inc.'s obligations and liabilities hereafter, and the rights and remedies of the customer are exclusive and is substitution for, and the customer waives all other warranties, guarantees, obligations, liabilities, rights and remedies, expressed or implied, arising by law or otherwise, including (without limitation) the implied warranties of merchantability or fitness or purpose, and any obligations or liability or Nitrous Express Inc. arising from tort, or loss of use, revenue or profit, or the incidental or consequential damage.

