



**2011+ Mustang Multi-Pump Fuel Hat
Part# SNF-60900**



Caution – EXTREME DANGER – Caution
Do not use or mix any Snow Performance products with any other manufacturer's products.

**THESE INSTRUCTIONS APPLY TO SNOW PERFORMANCE PRODUCTS ONLY!
FOR SANCTIONED RACE USE ONLY - NOT FOR SALE OR USE IN CALIFORNIA**

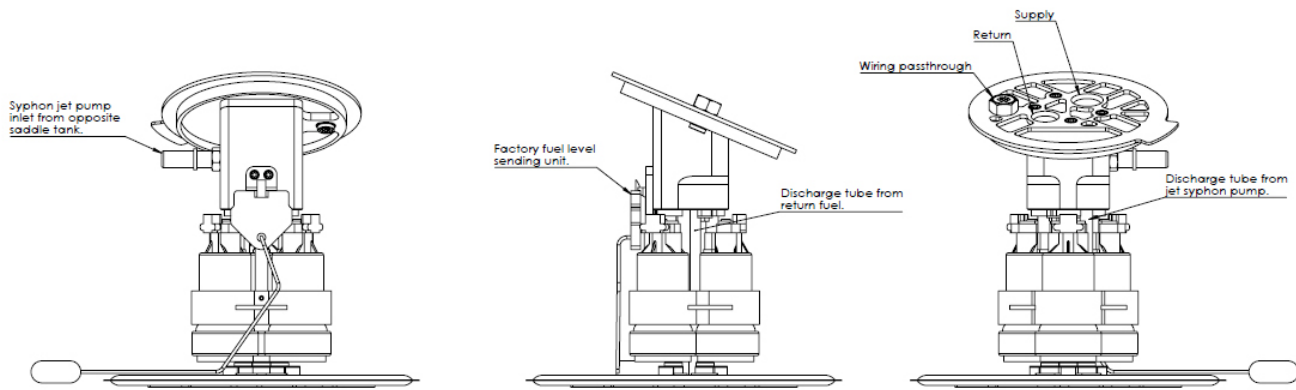

Installation:

1. To reduce spills and make installation easier and safer, the gas tank should be drained.
2. The fuel pump is underneath the driver rear seat. Slide the driver seat all the way forward. Squeeze the connection underneath the seat on both sides. Pull forward and lift the seat out of the vehicle.
3. Remove the seal of the access hole by gently pulling up in a circular fashion.
4. On top of the fuel pump housing, slide the electrical connector's red locking tab to the side.
5. Squeeze the tab and unplug the white connector. Relieve the pressure in fuel system by starting the engine and allowing it to stall. Remove the gas tank fill cap to relieve any residual tank pressure.
6. Disconnect the battery to ensure a safe working environment when handling items within the fuel system.
7. Clean the top of the factory fuel pump assembly to ensure no foreign materials make their way into the fuel tank.
8. Pull the red lock out of the quick connect fitting on the fuel line. Squeeze the release tab and remove the line from the factory fuel pump assembly. (Be sure to clean away or contain any fuel that may have spilled).
9. To release the OEM lock ring it is recommended to use the specified fuel tank lock ring tool for the application at hand.

NOTE: The Tank/Pump Setup pictured is from an S550 GT Mustang. Because the GT500 uses 2 fuel pumps, the 2-row connector (shown) is slightly different than other Ford models. The GT500 also has 2-connections for fuel transfer. All related steps still apply.

View toward the front of the vehicle



View toward the front of the vehicle



10. Some vehicles require you to bend back a section of the chassis for the OEM fuel pump removal. If necessary, bend one side of the access hole just enough for the OEM fuel tank lock ring to be removed. We can bend this back into place once we've finished.

11. Remove the OEM fuel tank lock ring. The OEM Ford pump assembly is spring-loaded and will pop up as soon as the lock ring is released.

12. Next, slowly remove the assembly. Do not bend or damage the fuel float arm. Once the float clears, the crossover hose will be visible. Release the tab and pull away the crossover hose.

13. Remove the OEM pump assembly and safely drain and contain any residual fuel in the assembly. Inspect the large green seal insuring it is not damaged or compromised.

Motorcraft P/N: CG-816

View toward the front of the vehicle



View toward the front of the vehicle

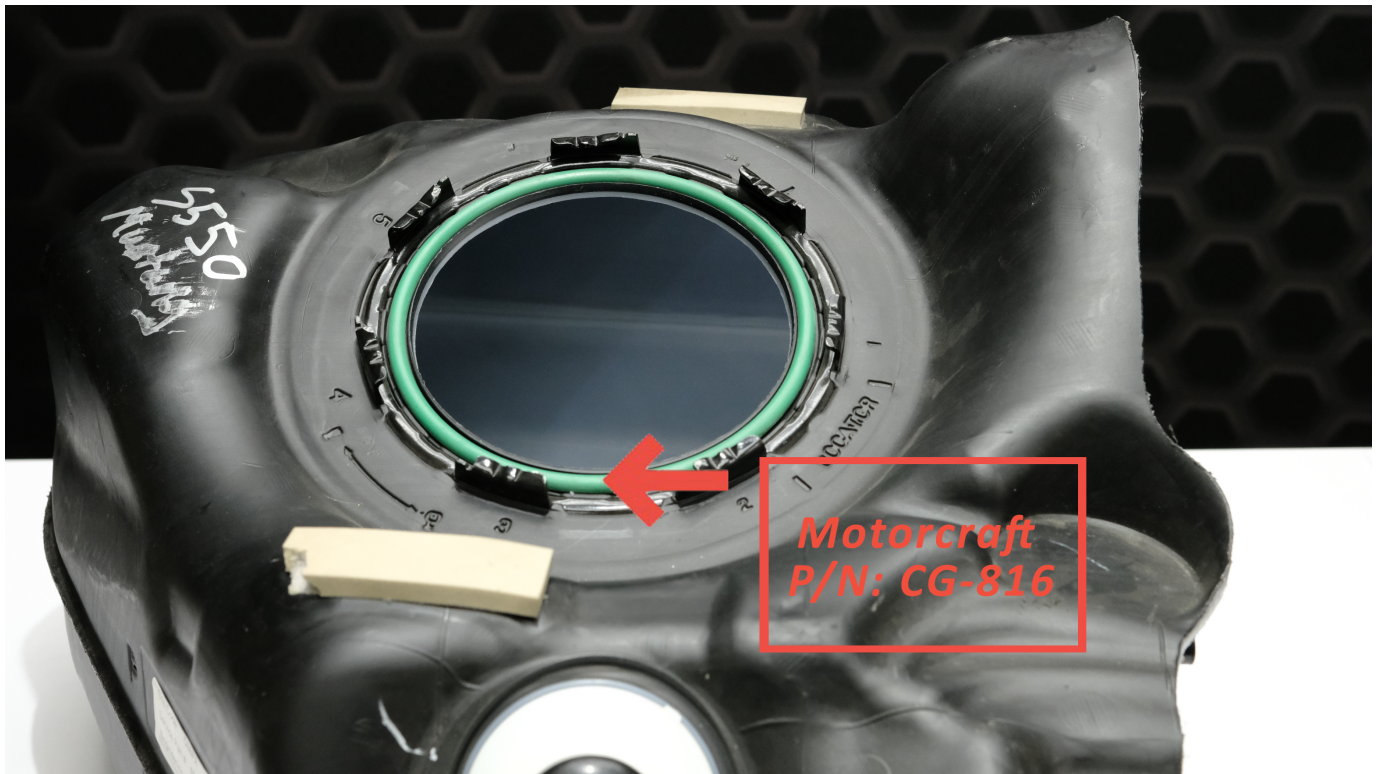

14. Be sure to cover the opening into the tank to ensure no trash enters the fuel system.

15. Now that the OEM pump assembly has been removed from the car, we will now remove the level sensor from the assembly itself. Press down to release the sensor. Release the 2-pin wiring thumb tab from under the upper plate and unplug the connector. The only parts that will be reused are the fuel level sender and the large gasket.

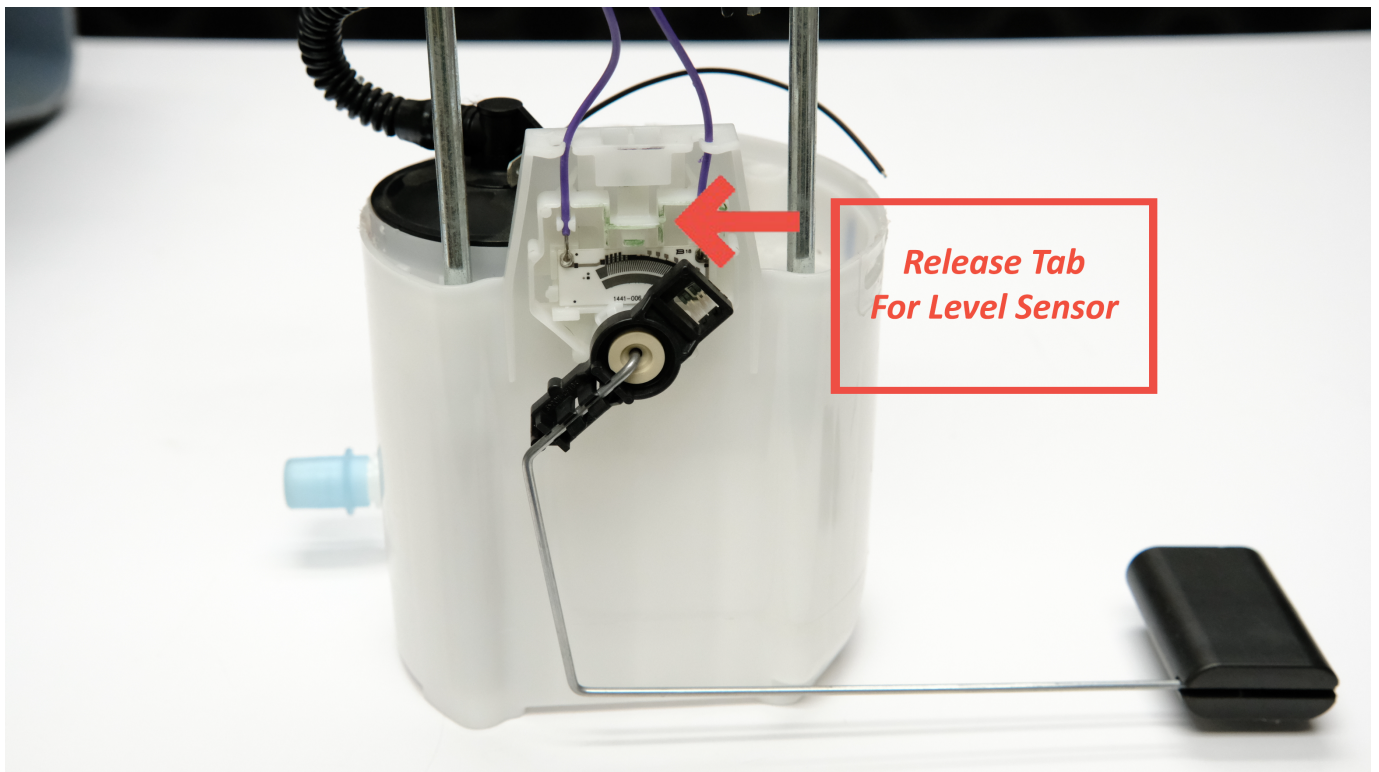

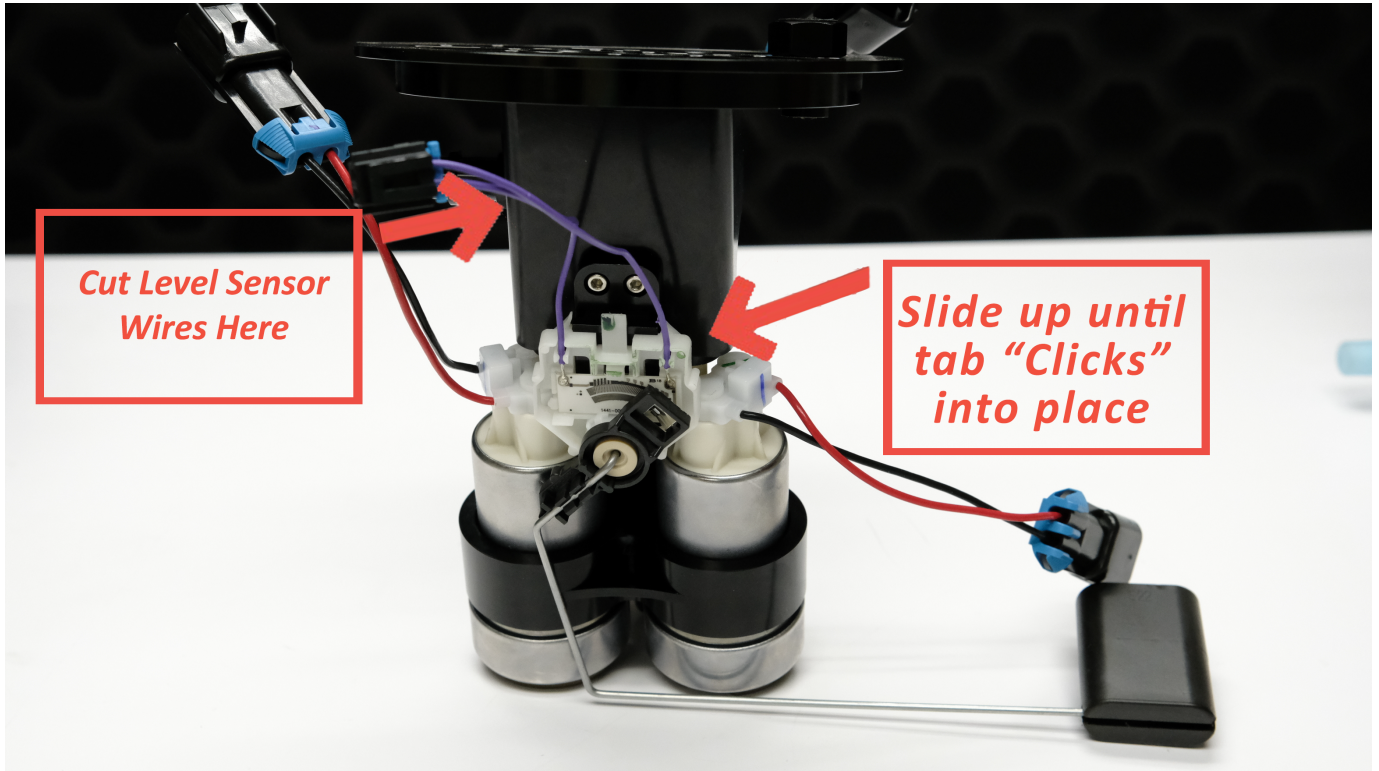

16. Cut the electrical connector off. Keep as much wire slack as possible, and proceed to strip the wires.

17. Wire polarity is not specific to the level sensor. We will connect the level sensor wires in a fashion similar to its previous state simply by soldering the wires back together and securing the contact with heat shrink. Connect to the White & Blue wires.

18. Secure the fuel level sensor, and slide it into place on the Snow Performance assembly from the bottom until it clicks..

19. Install the green O-ring gasket into the recessed area and pull the OEM crossover hose out of the gas tank, as shown.

20. Push the OEM crossover line over the quick connector until it “clicks” in place.

NOTE: *GT500 Models have 2-lines to connect. The lines are specific to its size, and cannot be connected incorrectly.*



View toward the front of the vehicle



21. Tilt the assembly so the fuel level float and crossover line fit into the tank. NOTE: To prevent fuel level float arm interference, make sure the crossover hose is rotated toward the rear of the vehicle.

22. Carefully lower the fuel pump assembly until the top hat fully seats onto the gas tank opening. It is normal to have a slight interference with the fuel level sensor. When sliding the fuel level sensor past the tank opening, gently push the sensor inward. For proper orientation, reference the Snow Performance logo or the images that follow.

23. Using the proper tool and socket wrench, reinstall the lock ring, as well as all other lines and connectors.

24. Proceed with wiring using the diagram below as reference. This representation is most accurately used with our Multi-Pump Relay Module (Part# SNF*-20003).

SNOW PERFORMANCE FUEL SYSTEMS

NOTE: Popular Example

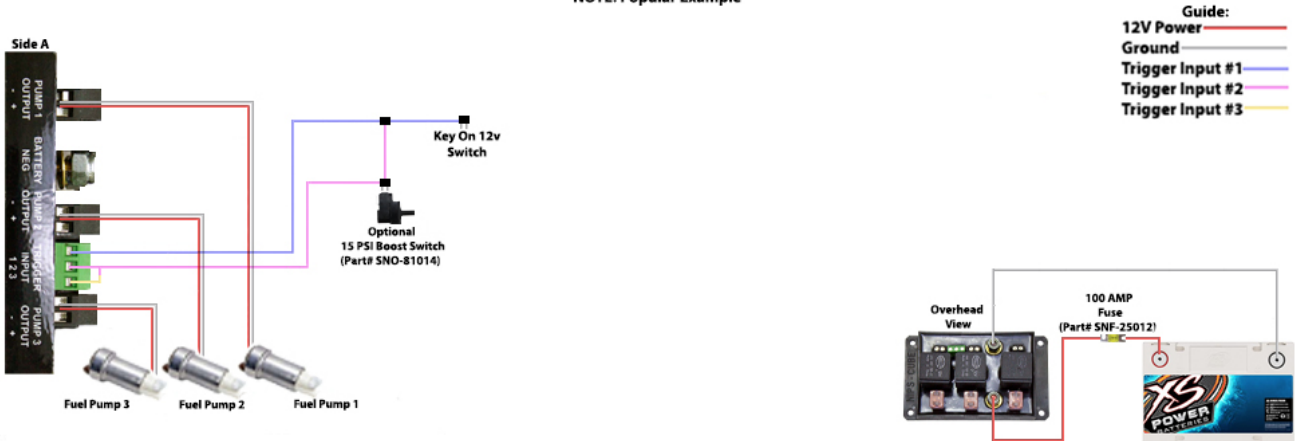

25. Reconnect the battery and turn the ignition key to the ON position. Confirm the new fuel pump(s) prime for a few seconds and inspect the car for leaks. If no leaks are found, start the vehicle. The engine may run rough for a few seconds until all the air is bled from the fuel system. Reinstall the OEM cover plate, the rear seat, and you have officially completed the installation!

Popular Routing Example:

